



L-Serie Liquid Ring



L-BV54



Liquid ring pump with high water carryover

The new liquid ring vacuum pumps (block pumps) Elmo Rietschle L-BV54 can carry over large quantities of liquid – up to 6 m³/h.

No pre-separation needed

The effort required for pre-separation of liquids is reduced or pre-separation can be completely eliminated. The use of an additional water pump is no longer required in most cases.

Very high volume flow

The Elmo Rietschle pumps primarily prove themselves in applications with damp process gases. They are characterized by an extremely high volume flow (up to 340 m³/h) and achieve intake pressures of 100 mbar (abs.).

Energy-saving

Optimizations of the flow geometry in the block pumps have led to very low power requirements and extremely low noise levels. The single-stage, compact, rugged design minimizes the space needed and ensures virtually maintenance-free operation.

Enormous reduction in costs

The benefits are obvious. Liquid ring vacuum pumps L-BV54 will considerably reduce your costs for installation, operation and service.

- Comprehensive logistics
- On-time delivery
- Quick response times
- Designed and manufactured in Germany

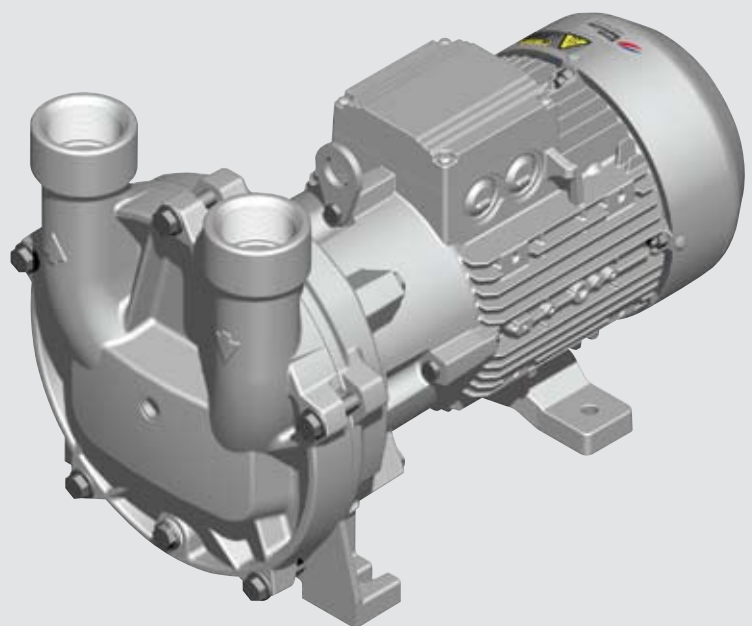



Leading in excellence

Advantages at a glance

- High water carryover of up to 6 m³/h
- No need for pre-separation
- Very high volume flow
- Worldwide use thanks to voltage range motors
- Low power requirement
- Extremely low noise level
- Enormous reduction in costs for installation, operation and service

Main applications

EPS foaming (molded parts of Styrofoam)

To avoid the deformation of the EPS molded parts, which result from a polymerization of polystyrene pellets, they are cooled with water.

Calibration tables (manufacturing of plastic profiles and plastic pipes)

Thermoplastic compound is calibrated and cooled with mold force using the L-BV54.

Technical data

- Intake volume flow: 90 – 340 m³/h
- Intake pressure (min.): 100 mbar (abs.)
- Noise level (50 Hz): < 70 dB(A)
- High water carryover (max.): 6 m³/h



**Gardner
Denver**

Elmo Rietschle is a brand of the
Gardner Denver Blower Division

Gardner Denver Schopfheim GmbH

Roggenbachstraße 58
79650 Schopfheim · Germany
Tel. +49 7622 392-0
Fax +49 7622 392-300

www.gd-elmorietschle.com · er.de@gardnerdenver.com

Gardner Denver Deutschland GmbH

Industriestraße 26
97616 Bad Neustadt · Germany
Tel. +49 9771 6888-0
Fax +49 9771 6888-4000