

G-Series Side Channel



**Elmo
Rietschle**
A Gardner Denver Product





G-BH1 00



G-BH1
single stage



G-BH1
double stage



G-BH2 VELOCIS
single, double and triple stage



G-BH7
single stage



G-SAH/G-SAP
single stage



G-SMV
multi stage

Side channel blowers

Some technologies are so good that it is hard to improve them. Side channel blowers from Elmo Rietschle are such an example. They have proven their reliability in service for many decades, performing flawlessly day in and day out with virtually no down time. Noise levels have been lower than that of most other vacuum pumps and compressors.

Our side channel blowers are available in a wide selection for performance ranges up to 1,766 cfm at 60 Hz and differential pressures of up to 402 in. H₂O. They cover the most varied requirements flexibly and powerfully.

The G-Series side channel blowers feature voltage range motors for 50 and 60 Hz in protection class IP 55 (insulation class F) and are UL 507 and CSA 22.2 No. 113 approved. This makes them the ideal solution for worldwide use: They can be used without modifications or tests in Europe, Asia and America. Most models are available from Hanover stock.

Advantages at a glance

- Reliable and built-to-last, virtually maintenance free
 - > Up to 20,000 operating hours without maintenance down time for G-BH1 00, G-BH1 and G-BH7
 - > Up to 40,000 operating hours without maintenance down time for G-BH2
- Robust yet light weight
- For use worldwide (UL/CSA/IEC/EN approval)
- 50/60 Hz motors
- Adjustable speed via external or integral frequency converter for all G-BH models

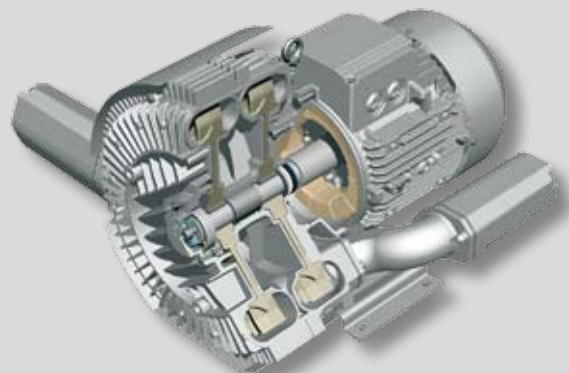



Applications

Central vacuum systems

Degasification of food

Dental vacuum

Drying out buildings

Filling bags / bottles / silos

Fishpond ventilation

Gas analysis

Industrial vacuum cleaners

Laser printers

Pneumatic conveying

- Conveying granulated material and powdery media

Letter sorting / enveloping

Lifting and holding parts using vacuum suction

Packaging industry

- Assembling and folding packaging materials
- Vacuum packaging

Plastics industry

- Contact free plastic film redirection
- Cooling and drying extruder products
- EPS foaming
- Granulate conveying
- Plastic welding
- Thermoforming

Printing and paper industry

- Sheet separation, turning, transport, fixation, and drying

Soil remediation

Swimming pool technology / jacuzzis

Textile industry

Ventilation of sewage treatment plants

Product overview

G-BH1 00

The smallest side channel blower on the market

With a height and width of approx. 4.9 inches and a depth of approx. 2.4 inches, the G-BH1 00 blowers are the smallest side channel blowers available on the market.

G-BH1

Classics with innovative technology

With their high inlet volume flow up to 1,413 cfm and a differential pressure of up to 313 in. H₂O, our low noise G-BH1 side channel blowers have earned their reputation. They are reliable, low maintenance and durable. They deliver 20,000 operating hours without fail and are virtually maintenance free.

G-BH2 VELOCIS

The side channel revolution

Volume flow up to 500 cfm and differential pressure up to 341 in. H₂O. With its significantly expanded range of performance, the side channel technology can now be used in completely new fields of application that were previously inconceivable. They deliver 40,000 operating hours without fail and are virtually maintenance free.

G-BH7

Unsurpassed at highest differential pressure

Our high performance G-BH7 side channel blowers can create differential pressure of up to 141 in. H₂O. They deliver 20,000 operating hours without fail and are virtually maintenance free.

G-SAH

Double stage side channel blowers

Capacities up to 64.7 cfm, differential pressure up to 173 in. H₂O. Integral silencer and suction mesh. High efficiency, low noise level.

G-SAP

Single stage side channel blowers

Capacities up to 318 cfm, differential pressure up to 402 in. H₂O. Integral silencer and suction mesh. High efficiency, low noise level.

G-SMV

Multi stage side channel vacuum pump

Capacities ranging from 176 cfm to 330 cfm and ultimate vacuum of 321 in. H₂O.

Technical specifications

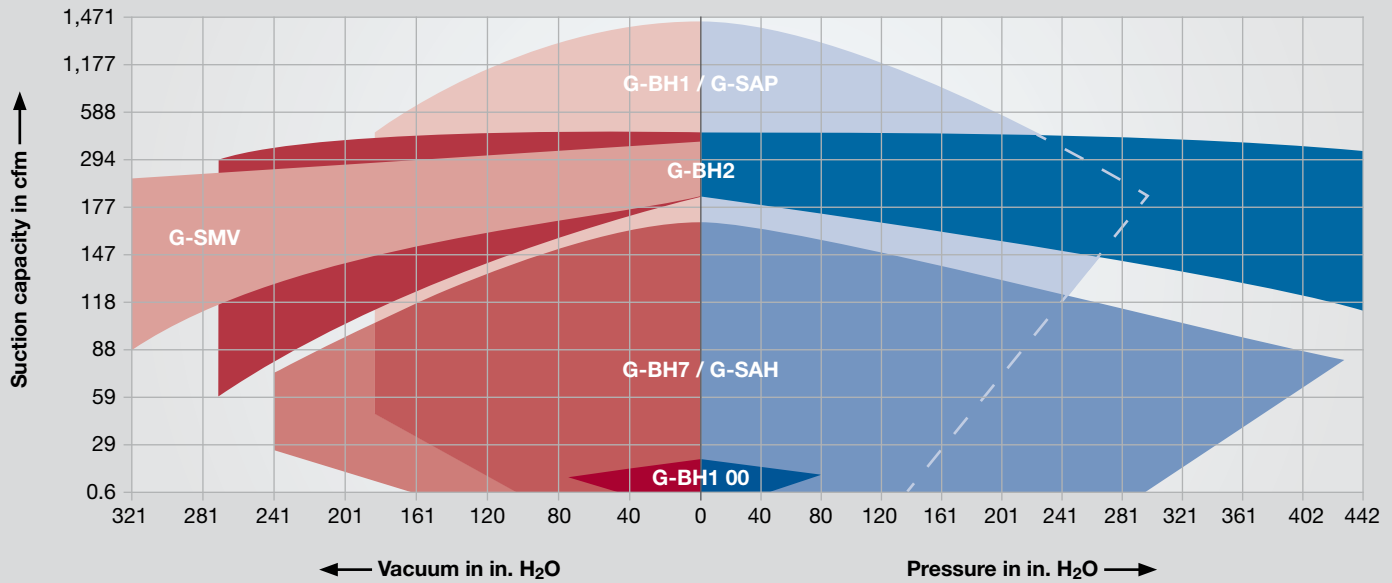

Operating principle

The impellers in the G-Series machines are mounted directly on the motor shaft for contact free compression. Maximum operational reliability, even at high differential pressures, is ensured by the arrangement of the bearings outside the compression chamber.

The gas is taken in through the inlet (1). As it enters the side channel (2), the rotating impellor (3) imparts velocity to the gas in the direction of rotation. Centrifugal force in the impellor blades accelerates the gas outward and the pressure increases. Every rotation adds kinetic energy, resulting in further increase of pressure along the side channel. The side channel narrows at the rotor, sweeping the gas off the impellor blades and discharging it through the outlet silencer (4) where it exits the pump.

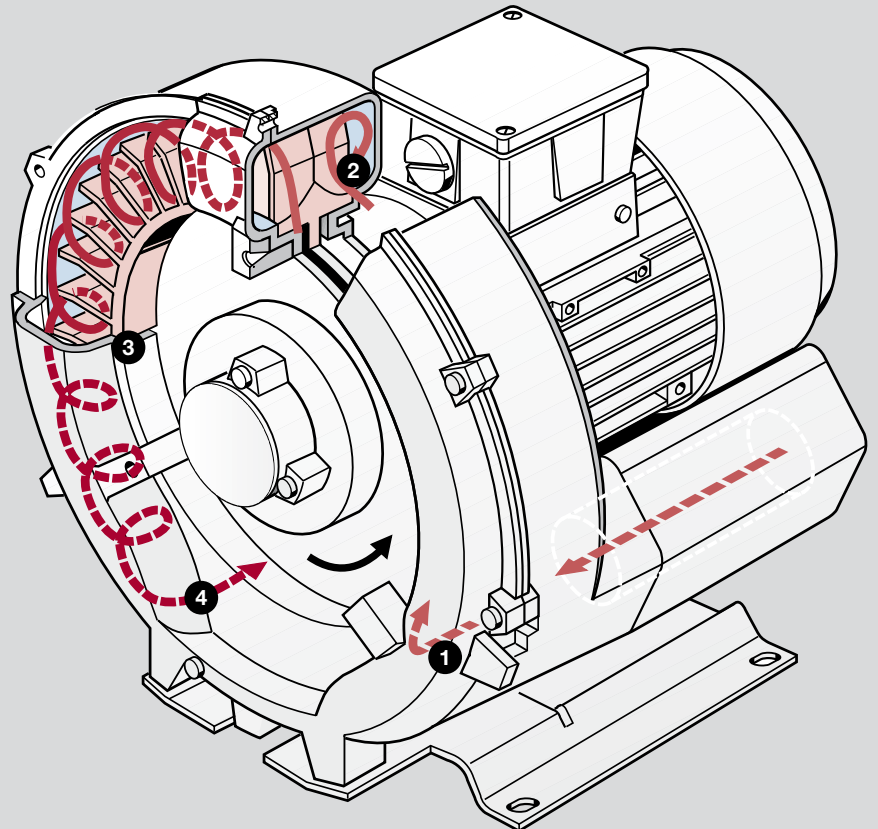



Technologies for all vacuum and pressure applications



F-Series Radial



G-Series Side Channel



L-Series Liquid Ring



V-Series Rotary Vane



R-Series Rotary Lobe



C-Series Claw



S-Series Screw



X-Series Systems

www.gd-elmorietschle.com

er.de@gardnerdenver.com

**Gardner Denver
Schopfheim GmbH**
Roggenbachstraße 58
79650 Schopfheim · Germany
Ph. +49 7622 392-0
Fax +49 7622 392-300

**Gardner Denver
Deutschland GmbH**
Industriestraße 26
97616 Bad Neustadt · Germany
Ph. +49 9771 6888-0
Fax +49 9771 6888-4000

**Gardner
Denver**

Elmo Rietschle is a brand of the
Gardner Denver Blower Division

Gardner Denver Hanover, Inc.
7222 Parkway Drive
Hanover, MD 21076 · USA
Ph. +1 410 712 4100
Fax +1 410 712 4148
hanover.sales@gardnerdenver.com