



Trocken laufende, berührungslos arbeitende Schrauben-Vakuumpumpen

Saugvermögen 110 bis 380 m³/h, max. Endvakuum 0,1 mbar (abs.).

Einfache Wartung.

Geeignet für industrielle Anwendungen wie Vakuumformen, Metallurgie und Oberflächentechnik.

Hoher Wirkungsgrad durch abgestuftes Schraubenprofil.

Ausführungen zum Fördern von Gasen mit erhöhtem Sauerstoffanteil sind verfügbar.

Dry running, non-contact operation screw vacuum pumps

Capacities ranging from 110 to 380 m³/hr, ultimate vacuum 0.1 mbar (abs.).

Easy to service.

Suitable for industrial applications like vacuum forming, metallurgy and surface technology.

High efficiency thanks to the precision graduation of the screw pitch.

Versions for handling of gases with raised oxygen-share are available.

Auswahldiagramm • Selection diagram 50 Hz

60 Hz

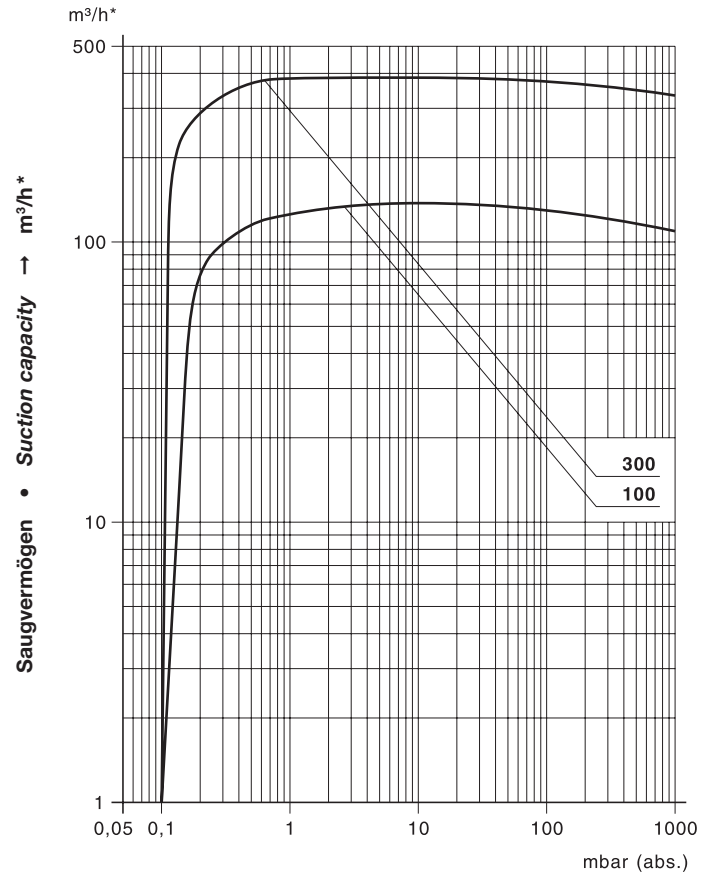
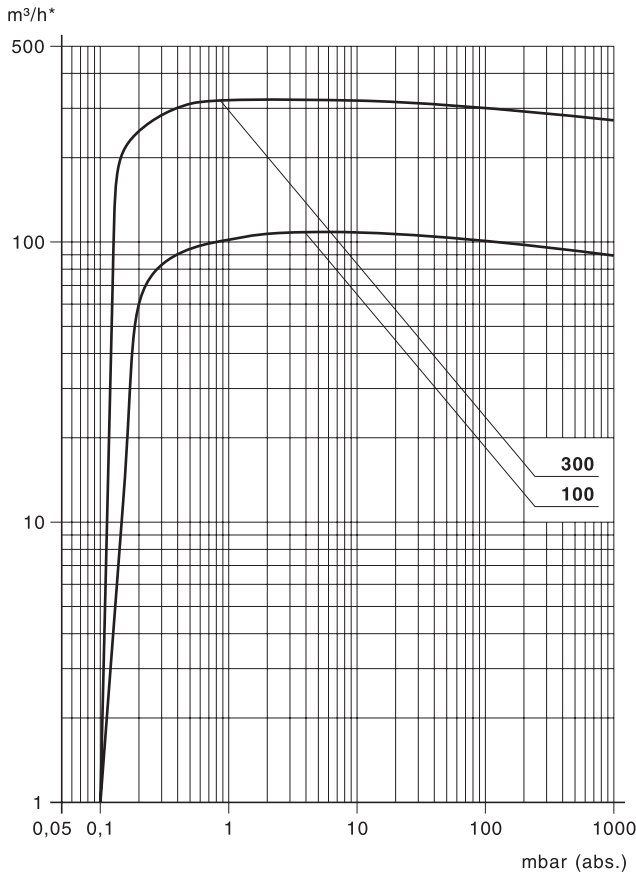

Ansaugdruck • Suction pressure → mbar (abs.)

S-VSI			100	300
Saugvermögen max. Suction capacity maximum	m ³ /h max.	50 Hz	110	320
		60 Hz	138	380
Enddruck Ultimate vacuum	mbar (abs.)		0,1	
Bemessungsspannung Rated voltage	3~	50 Hz	230/400V ± 10 %	
		60 Hz	220/380V	
Motorleistung Motor rating	kW	50 Hz	3,0	7,5
		60 Hz	3,6	9,0
Stromaufnahme Current drawn	A	50 Hz	10,5 / 6,0	14,6 / 8,4
		60 Hz	#	#
Drehzahl Speed	min ⁻¹	50 Hz	2880	
		60 Hz	3550	
Mittlerer Schalldruckpegel Average noise level	dB(A) EN ISO 3744	50 Hz	72	74
		60 Hz	75	78
Max. Gewicht Max. weight	kg		190	308
Öleinfüllmenge Oil capacity	l		1,65 (1,0 → H + 0,65 → H ₁)	1,9 (1,1 → H + 0,8 → H ₁)
Kühlwasserverbrauch Cooling water consumption	l/min		1,8	6,7

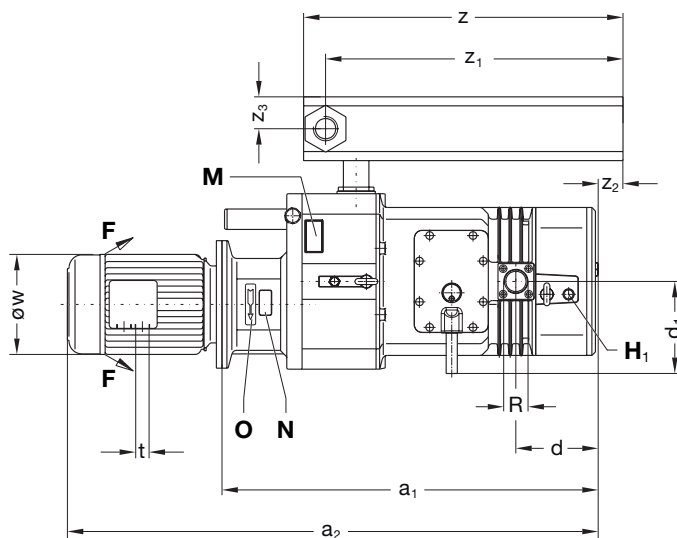
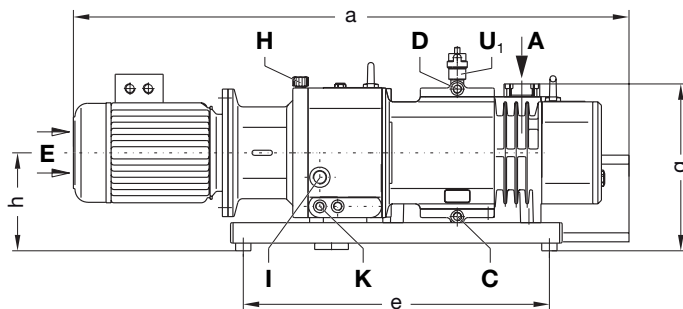
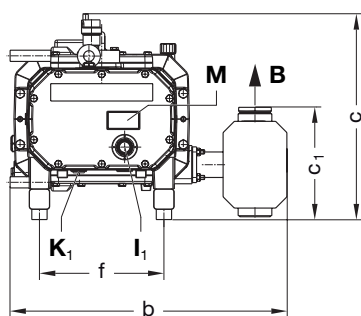

A	Vakuum-Anschluss • Vacuum connection
B	Abluft-Austritt • Exhaust
C	Kühlwassereintritt G 3/8 • Cooling water inlet
D	Kühlwasseraustritt G 3/8 • Cooling water outlet
E	Kühlluft-Eintritt • Cooling air entry
F	Kühlluft-Austritt • Cooling air exit
H, H₁	Öleinfüllstelle • Oil filling point
I, I₁	Ölkontrolle • Oil check
K, K₁	Ölablassstelle • Oil drain point
M	Ölempfehlungsschild • Oil type plate
N	Datenschild • Data plate
O	Drehrichtung • Direction of rotation
U₁	Schnellentlüftungsventil • Vent valve

S-VSI	100	300
a	1082	1442
a ₁	740	895
a ₂	1043	1261
b	542,5	671
c	403,5	442
c ₁	220	155
d	164	180
d ₁	179,5	205
e	600	940

S-VSI	100	300
f	244	270
g	332	380
h	197	225
t	M 32x1,5	M 32x1,5
øw	196	260
z / z ₁	626 / 576	835 / -
z ₂ / z ₃	39 / 62,5	181 / -
R	G 1 1/2	G 2 1/2

Zubehör • Accessories

S-VSI		100	300
Rückschlagventil Non-return valve	ZRK	40 (03)	65 (03)
Vakuumdichter Ansaugfilter Vacuum tight suction filter	ZVF	50 Hz 40 (53)	65 (52) 65 (52)
Motorschutzschalter Motor starter	ZMS	50 Hz 160 / 100 #	160 / 100 #
Sanftanlauf Soft starter	ZAD	#	#

m³/h* bezogen auf den Zustand im Sauganschluss • refers to suction conditions at inlet connection

Kennlinien, Tabellenangaben (Toleranz ±10%) sind ermittelt nach PNEUROP und beziehen sich auf betriebswarme Vakuumpumpen. • Curves, tables content (tolerance ±10%) according to PNEUROP standards and refer to vacuum pump at normal operating temperature.

Die Motor-Abmessungen sowie die Stromaufnahme können je nach Motorfabrikat abweichen. • The motor dimensions as well as the current drawn can differ depending on the motor type.

auf Anfrage • # on request

Technische Änderungen vorbehalten! • We reserve the right to alter technical information!