

WVB / WPB 120 (01)

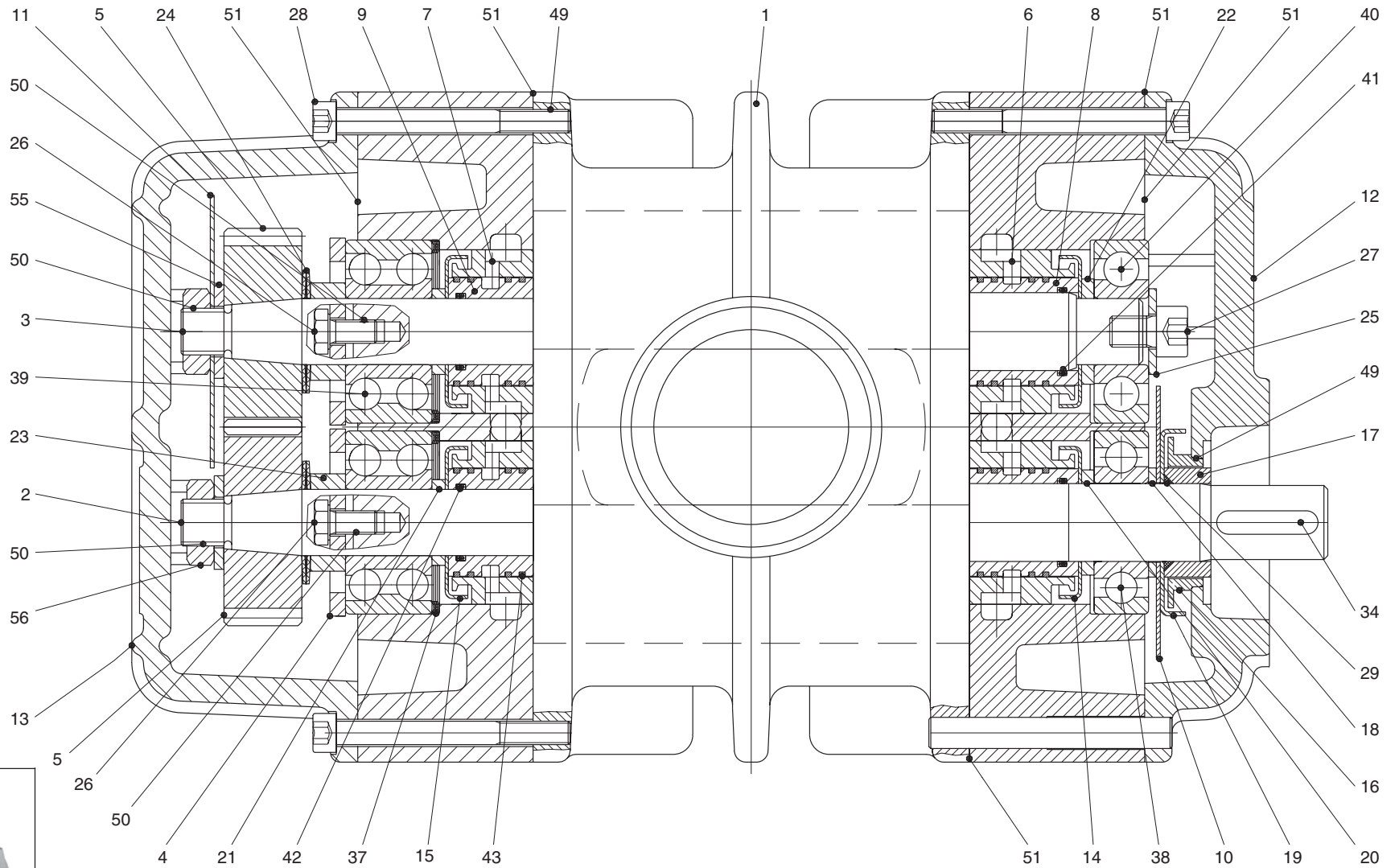

SHARK

WVB (01)

WPB (01)



E 851/1

1.1.2001

	Grundteile	Basic parts	Elément de base	Parti fondamentali					
1	Gehäuse	Housing	Corps	Corpo pompa	31	Verschluss-Stopfen M 12 x 1,5	Plug	Ecrou obturateur	Tappo
2	Drehkolben 'A	Rotary piston 'A	Piston rotatif 'A	Pistone rotante 'A	34	Passfeder 8 x 7 x 40	Key	Clavette	Chiavetta
3	Drehkolben 'B	Rotary piston 'B	Piston rotatif 'B	Pistone rotante 'B	37	Federscheibe 46,5 x 40 x 0,4	Spring shim	Rondelle ressort	Disco a molla
4	Lagerdeckel	Bearing cover	Couvercle palier	Coperchio cuscinetti	39	V Rillenkugellager	Deep groove ball bearing	Roulement aiguille	Cuscinetto a sfera
5	Zahnrad	Gear wheel	Roue dentée	Ruota dentata	39	V Zweireih. Rillenkugellager	Deep groove ball bearing	Roulement aiguille	Cuscinetto a sfera
6	Abdichtung 'A	Seal 'A	Étanchéité 'A	Otturazione 'A	40	V Rillenkugellager	Deep groove ball bearing	Roulement aiguille	Cuscinetto a sfera
7	Abdichtung 'B	Seal 'B	Étanchéité 'B	Otturazione 'B	41	D O-Ring 20,35 x 1,78	O-Ring	Joint torique	O-Ring
8	Buchse 'A	Sleeve 'A	Douille 'A	Bussola 'A	42	D O-Ring 17 x 2	O-Ring	Joint torique	O-Ring
9	Buchse 'B	Sleeve 'B	Douille 'B	Bussola 'B	43	V Kolbenring	Piston ring	Bague de piston	Anello pistone
10	Schleuderscheibe 'A	Flinger 'A	Disque centrifuge 'A	Disco centrifugo 'A	44	V Ölschauglas	Oil sight glass	Voyant d'huile	Spia verifica
11	Schleuderscheibe 'B	Flinger 'B	Disque centrifuge 'B	Disco centrifugo 'B	49	Loctite-Schraubensicherung	Screw protection	Protection vis	Protezione di viti
12	Deckel 'A	Cover 'A	Couvercle 'A	Coperchio 'A	50	Loctite-Schraubensicherung	Screw protection	Protection vis	Protezione di viti
13	Deckel 'B	Cover 'B	Couvercle 'B	Coperchio 'B	51	Loctite-Schraubensicherung	Screw protection	Protection vis	Protezione di viti
14	Spritzscheibe 'A	Splash disc 'A	Disque pulvérisateur 'A	Disco spruzzatore 'A	55	Unterlegscheibe	Washer	Rondelle	Rondella
15	Spritzscheibe 'B	Splash disc 'B	Disque pulvérisateur 'B	Disco spruzzatore 'B	56	Mutter M 12 x 1,25	Nut	Ecrou	Madrevite dado
16	Gleitring	Sliding ring	Bague de lubrification	Anello di scorrimento					
17	Buchse	Sleeve	Douille	Bussola					
18	Distanzring	Spacer ring	Rondelle entretoise	Anello distanziatore					
19	Spritzscheibe	Splash disc 'B	Disque pulvérisateur 'B	Disco spruzzatore 'B					
20	Distanzring '1	Spacer ring '1	Rondelle entretoise '1	Anello distanziatore '1					
21	Distanzring '2	Spacer ring '2	Rondelle entretoise '2	Anello distanziatore '2					
22	Distanzring '3	Spacer ring '3	Rondelle entretoise '3	Anello distanziatore '3					
23	Distanzring '4	Spacer ring '4	Rondelle entretoise '4	Anello distanziatore '4					
24	Spannscheibe	Spring washer	Rondelle tendeur	Disco di fissaggio					
25	Scheibe	Disc	Rondelle	Disco					
26	Sechskantschraube M 6 x 12	Hexagon head screw	Vis six pans	Vite con testa esagonale					
27	Innen-Sechskantschraube M 8 x 12	Allen screw	Vis 6 pans creuse	Vite a brugola esagonale					
28	Innen-Sechskantschraube M 6 x 60	Allen screw	Vis 6 pans creuse	Vite a brugola esagonale					
29	D O-Ring 18 x 2	O-Ring	Joint torique	O-Ring					
30	D Dichtring 12 x 16 x 1,5	Sealing ring	Anneau d'étanchéité	Anello di tenuta					

Bei Bestellungen folgendes angeben: Typ, Fabrikations-Nr., Positions-Nr., Motor (kW, V, Hz)

To order please indicate: model, serial-no., item-no., motor (kW, V, Hz)

En cas de commande préciser: type d'appareil, no. de position des pièces, moteur (kW, V, Hz)

Nell'ordine indicare: tipo, numero di matricola, numero di posizione dei ricambi, motore (kW, V, Hz)

V = Verschleißteile

V = Wearing parts

V = Pièces d'usure

V = Parti usurabili

D = Dichtungen

D = Seals

D = Joints

D = Guarnizioni

Gardner Denver Schopfheim GmbH

Postfach 1260 • 79642 SCHOPFHEIM / GERMANY

Fon +49 7622 / 392-0 • Fax +49 7622 / 392-300

er.de@gardnerdenver.com • www.gd-elmorietschle.com

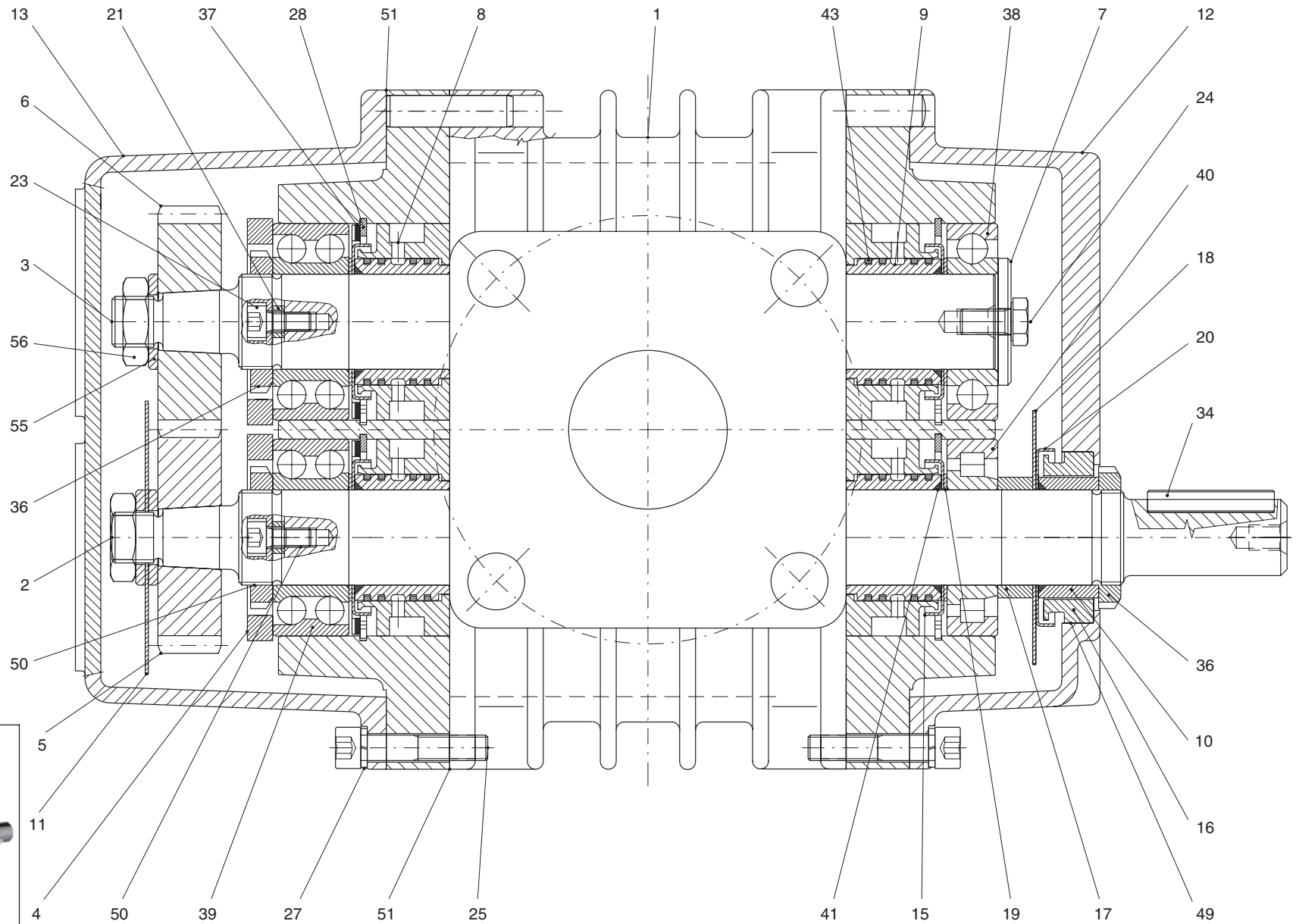

SHARK

WVB (01)

WPB (01)



	Grundteile	Basic parts	Elément de base	Parti fondamentali					
	Gehäuse	Housing	Corps	Corpo pompa	34	Passfeder 8 x 7 x 40	Key	Clavette	Chiavetta
1	Drehkolben 'A	Rotary piston 'A	Piston rotatif 'A	Pistone rotante 'A	36	Nutmutter KM 6	Groove nut	Ecrou mortaise	Dado cilindrico ad intagli
2	Drehkolben 'B	Rotary piston 'B	Piston rotatif 'B	Pistone rotante 'B	37	Federscheibe 61 x 51 x 0,4	Spring shim	Rondelle ressort	Disco a molla
3	Lagerdeckel	Bearing cover	Couvercle palier	Coperchio cuscinetti	39	V Rillenkugellager	Deep groove ball bearing	Roulement aiguille	Cuscinetto a sfera
4	Zahnrad 'treibend	Gear wheel 'driving	Roue dentée	Ruota dentata trainante	39	V Zweireih. Rillenkugellager	Deep groove ball bearing	Roulement aiguille	Cuscinetto a sfera
5	Zahnrad 'getrieben	Gear wheel 'driven	Roue dentée	Ruota dentata trainata	40	V Rillenkugellager	Deep groove ball bearing	Roulement aiguille	Cuscinetto a sfera
6	Scheibe	Disc	Rondelle	Disco	41	D O-Ring 30 x 2	O-Ring	Joint torique	O-Ring
7	Abdichtung 'B	Seal 'B	Étanchéité 'B	Otturazione 'B	43	V Kolbenring	Piston ring	Bague de piston	Anello pistone
8	Buchse	Sleeve	Douille	Bussola	44	V Ölschauglas	Oil sight glass	Voyant d'huile	Spia verifica
9	Buchse 'A	Sleeve 'A	Douille 'A	Bussola 'A	49	Loctite-Schraubensicherung	Screw protection	Protection vis	Protezione di viti
10	Schleuderscheibe 'B	Flinger 'B	Disque centrifuge 'B	Disco centrifugo 'B	50	Loctite-Schraubensicherung	Screw protection	Protection vis	Protezione di viti
11	Deckel 'A	Cover 'A	Couvercle 'A	Coperchio 'A	51	Loctite-Schraubensicherung	Screw protection	Protection vis	Protezione di viti
12	Deckel 'B	Cover 'B	Couvercle 'B	Coperchio 'B	52	Dichtungsband	Sealing band	Feuillard étanchéité	Molla albero
13	Spritzscheibe	Splash disc	Disque pulvérisateur	Disco spruzzatore	55	Unterlegscheibe	Washer	Rondelle	Rondella
15	Gleitring	Sliding ring	Bague de lubrification	Anello di scorrimento	56	Mutter M 16 x 1,5	Nut	Ecrou	Madrevite dado
16	Distanzring	Spacer ring	Rondelle entretoise	Anello distanziatore					
17	Schleuderscheibe 'A	Flinger 'A	Disque centrifuge 'A	Disco centrifugo 'A					
18	Scheibe	Disc	Rondelle	Disco					
19	Spritzscheibe	Splash disc	Disque pulvérisateur	Disco spruzzatore					
20	Ring	Ring	Anneau	Anello					
21	Innen-Sechskantschraube M 6 x 14	Allen screw	Vis 6 pans creuse	Vite a brugola esagonale					
23	Sechskantschraube M 8 x 16	Hexagon head screw	Vis six pans	Vite con testa esagonale					
24	Innen-Sechskantschraube M 8 x 40	Allen screw	Vis 6 pans creuse	Vite a brugola esagonale					
25	Federring	Spring ring	Anneau ressort	Rosetta elastica					
26	Sicherungsring	Lock ring	Circlip	Anello di sicurezza					
27	Dichtring 10 x 14 x 1	Sealing ring	Anneau d'étanchéité	Anello di tenuta					
28	Dichtring 12 x 16 x 1,5	Sealing ring	Anneau d'étanchéité	Anello di tenuta					
29	Verschluss-Stopfen M 12 x 1,5	Plug	Ecrou obturateur	Tappo					
30	Verschluss-Stopfen M 10 x 1	Plug	Ecrou obturateur	Tappo					

Bei Bestellungen folgendes angeben: Typ, Fabrikations-Nr., Positions-Nr., Motor (kW, V, Hz)

To order please indicate: model, serial-no., item-no., motor (kW, V, Hz)

En cas de commande préciser: type d'appareil, no. de position des pièces, moteur (kW, V, Hz)

Nell'ordine indicare: tipo, numero di matricola, numero di posizione dei ricambi, motore (kW, V, Hz)

V = Verschleißteile

V = Wearing parts

V = Pièces d'usure

V = Parti usurabili

D = Dichtungen

D = Seals

D = Joints

D = Guarnizioni

Gardner Denver Schopfheim GmbH

Postfach 1260 • 79642 SCHOPFHEIM / GERMANY

Fon +49 7622 / 392-0 • Fax +49 7622 / 392-300

er.de@gardnerdenver.com • www.gd-elmorietschle.com

WVB / WPB 550 (01) + WVB / WPB 750 (01)

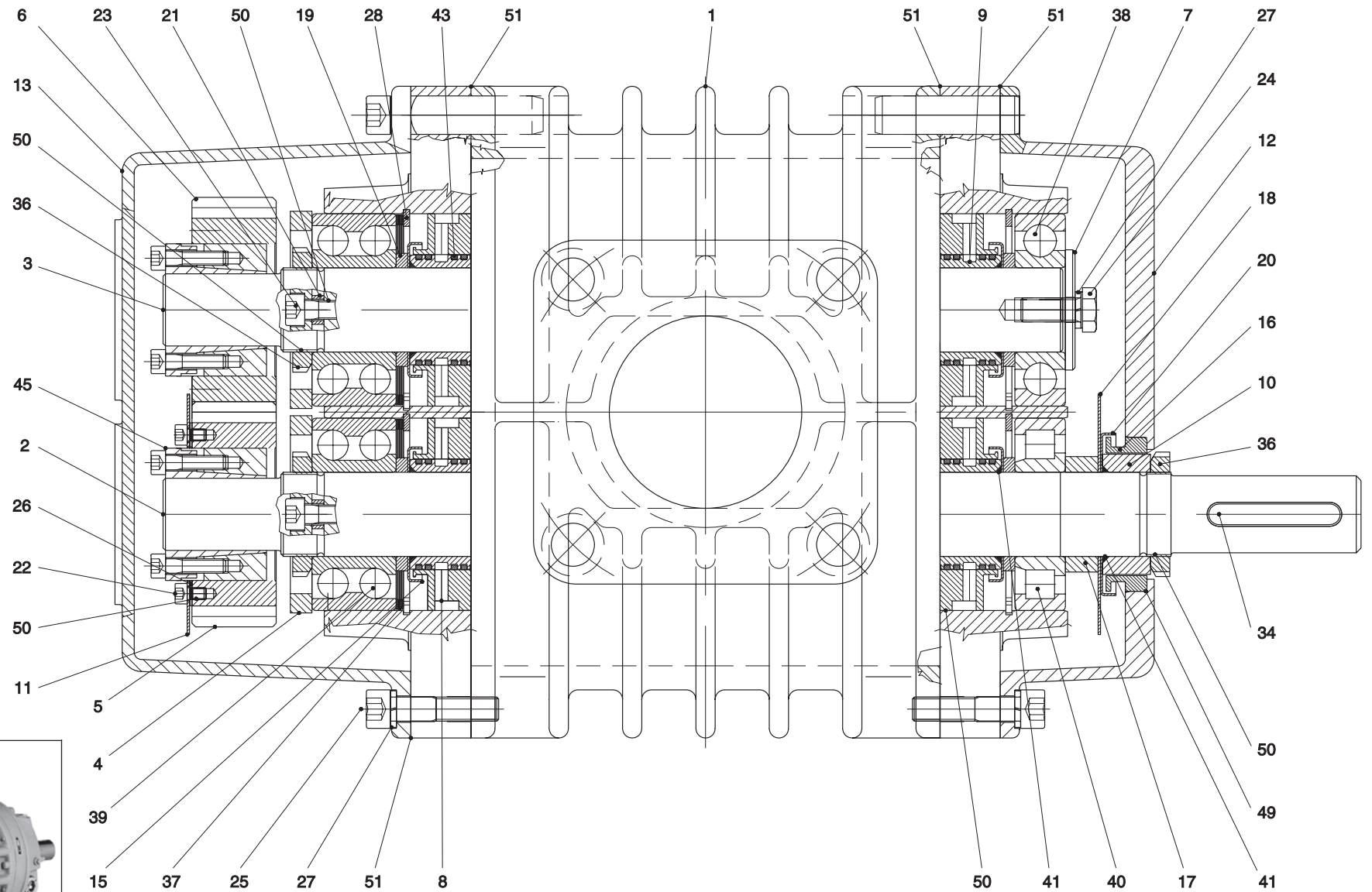

SHARK

WVB (01)

WPB (01)



E 851/3

1.1.2001

	Grundteile	Basic parts	Elément de base	Parti fondamentali					
1	Gehäuse	Housing	Corps	Corpo pompa	31	Verschluss-Stopfen M 12 x 1,5	Plug	Ecrou obturateur	Tappo
2	Drehkolben 'A	Rotary piston 'A	Piston rotatif 'A	Pistone rotante 'A	32	Verschluss-Stopfen M 10 x 1	Plug	Ecrou obturateur	Tappo
3	Drehkolben 'B	Rotary piston 'B	Piston rotatif 'B	Pistone rotante 'B	34	Passfeder 10 x 8 x 50	Key	Clavette	Chiavetta
4	Lagerdeckel	Bearing cover	Couvercle palier	Coperchio cuscinetti	36	Nutmutter KM 7	Groove nut	Ecrou mortaise	Dado cilindrico ad intagli
5	Zahnrad 'treibend	Gear wheel 'driving	Roue dentée	Ruota dentata trainante	37	Federscheibe 79 x 70,6 x 0,6	Spring shim	Rondelle ressort	Disco a molla
6	Zahnrad 'getrieben	Gear wheel 'driven	Roue dentée	Ruota dentata trainata	38	V Rillenkugellager	Deep groove ball bearing	Roulement aiguille	Cuscinetto a sfera
7	Scheibe	Disc	Rondelle	Disco	39	V Zweireih. Rillenkugellager	Deep groove ball bearing	Roulement aiguille	Cuscinetto a sfera
8	Abdichtung 'B	Seal 'B	Étanchéité 'B	Otturazione 'B	40	V Zylinder-Rollenlager	Cylinder roller bearing	Roulement rouleaux cylindr.	Cuscinetto a rulli
9	Buchse	Sleeve	Douille	Bussola	41	D O-Ring 34 x 2	O-Ring	Joint torique	O-Ring
10	Buchse 'A	Sleeve 'A	Douille 'A	Bussola 'A	43	V Kolbenring	Piston ring	Bague de piston	Anello pistone
11	Schleuderscheibe 'B	Flinger 'B	Disque centrifuge 'B	Disco centrifugo 'B	44	V Ölschauglas	Oil sight glass	Voyant d'huile	Spia verifica
12	Deckel 'A	Cover 'A	Couvercle 'A	Coperchio 'A	45	Konus-Spannelement TLK 130	Conical-clamping element	Élément tendeur étoupe	Elemento di serraggio cavo
13	Deckel 'B	Cover 'B	Couvercle 'B	Coperchio 'B	49	Loctite-Schraubensicherung	Screw protection	Protection vis	Protezione di viti
15	Spritzscheibe	Splash disc	Disque pulvérisateur	Disco spruzzatore	50	Loctite-Schraubensicherung	Screw protection	Protection vis	Protezione di viti
16	Gleitring	Sliding ring	Bague de lubrification	Anello di scorrimento	51	Loctite-Schraubensicherung	Screw protection	Protection vis	Protezione di viti
17	Distanzring	Spacer ring	Rondelle entretoise	Anello distanziatore	52	Dichtungsband	Sealing band	Feuillard étanchéité	Molla albero
18	Schleuderscheibe 'A	Flinger 'A	Disque centrifuge 'A	Disco centrifugo 'A					
19	Scheibe	Disc	Rondelle	Disco					
20	Spritzscheibe	Splash disc	Disque pulvérisateur	Disco spruzzatore					
21	Ring	Ring	Anneau	Anello					
22	Innen-Sechskantschraube M 5 x 8	Allen screw	Vis 6 pans creuse	Vite a brugola esagonale					
23	Innen-Sechskantschraube M 8 x 16	Allen screw	Vis 6 pans creuse	Vite a brugola esagonale					
24	Sechskantschraube M 10 x 25	Hexagon head screw	Vis six pans	Vite con testa esagonale					
25	Innen-Sechskantschraube M 10 x 45	Allen screw	Vis 6 pans creuse	Vite a brugola esagonale					
27	Federring	Spring ring	Anneau ressort	Rosetta elastica					
28	Sicherungsring	Lock ring	Circlip	Anello di sicurezza					
29	D Dichtring 10 x 14 x 1	Sealing ring	Anneau d'étanchéité	Anello di tenuta					
30	D Dichtring 12 x 16 x 1,5	Sealing ring	Anneau d'étanchéité	Anello di tenuta					

Bei Bestellungen folgendes angeben: Typ, Fabrikations-Nr., Positions-Nr., Motor (kW, V, Hz)

To order please indicate: model, serial-no., item-no., motor (kW, V, Hz)

En cas de commande préciser: type d'appareil, no. de position des pièces, moteur (kW, V, Hz)

Nell'ordine indicare: tipo, numero di matricola, numero di posizione dei ricambi, motore (kW, V, Hz)

V = Verschleißteile

V = Wearing parts

V = Pièces d'usure

V = Parti usurabili

D = Dichtungen

D = Seals

D = Joints

D = Guarnizioni

Gardner Denver Schopfheim GmbH

Postfach 1260 • 79642 SCHOPFHEIM / GERMANY

Fon +49 7622 / 392-0 • Fax +49 7622 / 392-300

er.de@gardnerdenver.com • www.gd-elmorietschle.com

WVB / WPB 1000 (01) + WVB / WPB 1300 (01)

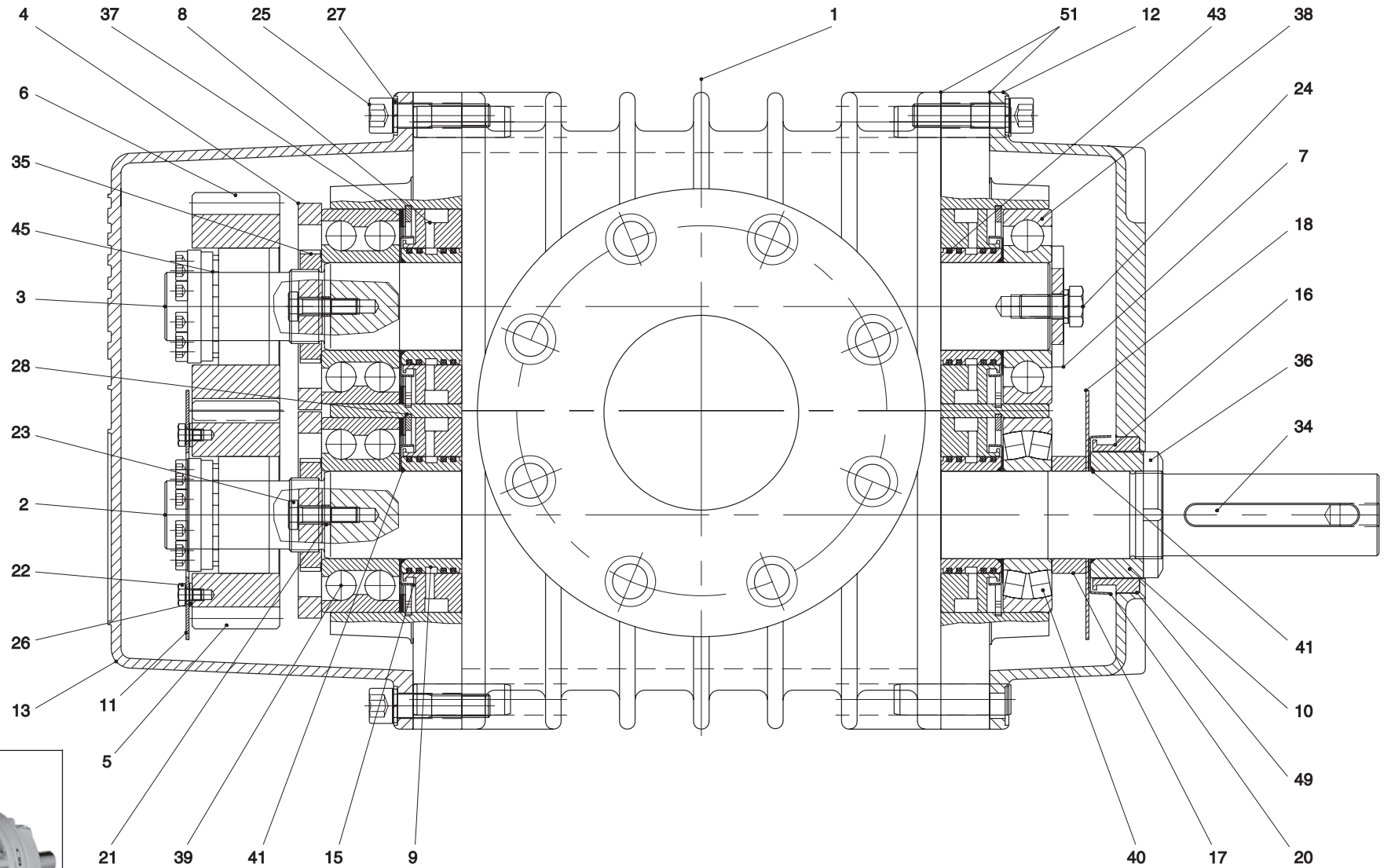

SHARK

WVB (01)

WPB (01)



E 851/4

1.1.2001

	Grundteile	Basic parts	Élément de base	Parti fondamentali					
1	Gehäuse	Housing	Corps	Corpo pompa	31	Verschluss-Stopfen M 12 x 1,5	Plug	Ecrou obturateur	Tappo
2	Drehkolben 'A	Rotary piston 'A	Piston rotatif 'A	Pistone rotante 'A	32	Verschluss-Stopfen M 10 x 1	Plug	Ecrou obturateur	Tappo
3	Drehkolben 'B	Rotary piston 'B	Piston rotatif 'B	Pistone rotante 'B	34	Passfeder 12 x 8 x 90	Key	Clavette	Chiavetta
4	Lagerdeckel	Bearing cover	Couvercle palier	Coperchio cuscinetti	35	Mutter M 38 x 1,5	Nut	Ecrou	Madrevite dado
5	Zahnrad 'treibend	Gear wheel 'driving	Roue dentée	Ruota dentata trainante	36	Nutmutter KM 9	Groove nut	Ecrou mortaise	Dado cilindrico ad intagli
6	Zahnrad 'getrieben	Gear wheel 'driven	Roue dentée	Ruota dentata trainata	37	Federscheibe 99,5 x 80,5 x 0,7	Spring shim	Rondelle ressort	Disco a molla
7	Scheibe	Disc	Rondelle	Disco					
8	Abdichtung 'B	Seal 'B	Étanchéité 'B	Otturazione 'B	38	V Rillenkugellager	Deep groove ball bearing	Roulement aiguille	Cuscinetto a sfera
9	Buchse	Sleeve	Douille	Bussola	39	V Zweireih. Rillenkugellager	Deep groove ball bearing	Roulement aiguille	Cuscinetto a sfera
10	Buchse 'A	Sleeve 'A	Douille 'A	Bussola 'A	40	V Pendelkugellager	Self-aligning ball-bearing	Roulement à billes articulé	Cuscinetto a sfera
11	Schleuderscheibe 'B	Flinger 'B	Disque centrifuge 'B	Disco centrifugo 'B	41	D O-Ring 45 x 2	O-Ring	Joint torique	O-Ring
12	Deckel 'A	Cover 'A	Couvercle 'A	Coperchio 'A	43	V Kolbenring	Piston ring	Bague de piston	Anello pistone
13	Deckel 'B	Cover 'B	Couvercle 'B	Coperchio 'B	44	V Ölschauglas	Oil sight glass	Voyant d'huile	Spia verifica
15	Spritzscheibe	Splash disc	Disque pulvérisateur	Disco spruzzatore	45	Konus-Spannelement TLK 130	Conical-clamping element	Élément tendeur étoupe	Elemento di serraggio cavo
16	Gleitring	Sliding ring	Bague de lubrification	Anello di scorrimento	49	Loctite-Schraubensicherung	Screw protection	Protection vis	Protezione di viti
17	Distanzring	Spacer ring	Rondelle entretoise	Anello distanziatore	50	Loctite-Schraubensicherung	Screw protection	Protection vis	Protezione di viti
18	Schleuderscheibe 'A	Flinger 'A	Disque centrifuge 'A	Disco centrifugo 'A	51	Loctite-Schraubensicherung	Screw protection	Protection vis	Protezione di viti
20	Spritzscheibe	Splash disc	Disque pulvérisateur	Disco spruzzatore					
21	Ring	Ring	Anneau	Anello					
22	Sechskantschraube M 6 x 8	Hexagon head screw	Vis six pans	Vite con testa esagonale					
23	Sechskantschraube M 8 x 30	Hexagon head screw	Vis six pans	Vite con testa esagonale					
24	Sechskantschraube M 12 x 25	Hexagon head screw	Vis six pans	Vite con testa esagonale					
25	Innen-Sechskantschraube M 12 x 50	Allen screw	Vis 6 pans creuse	Vite a brugola esagonale					
26	Scheibe	Disc	Rondelle	Disco					
27	Federring	Spring ring	Anneau ressort	Rosetta elastica					
28	Sicherungsring	Lock ring	Circlip	Anello di sicurezza					
29	D Dichtring 10 x 14 x 1	Sealing ring	Anneau d'étanchéité	Anello di tenuta					
30	D Dichtring 12 x 16 x 1,5	Sealing ring	Anneau d'étanchéité	Anello di tenuta					

Bei Bestellungen folgendes angeben: Typ, Fabrikations-Nr., Positions-Nr., Motor (kW, V, Hz)

To order please indicate: model, serial-no., item-no., motor (kW, V, Hz)

En cas de commande préciser: type d'appareil, no. de position des pièces, moteur (kW, V, Hz)

Nell'ordine indicare: tipo, numero di matricola, numero di posizione dei ricambi, motore (kW, V, Hz)

V = Verschleißteile

V = Wearing parts

V = Pièces d'usure

V = Parti usurabili

D = Dichtungen

D = Seals

D = Joints

D = Guarnizioni

Gardner Denver Schopfheim GmbH

Postfach 1260 • 79642 SCHOPFHEIM / GERMANY

Fon +49 7622 / 392-0 • Fax +49 7622 / 392-300

er.de@gardnerdenver.com • www.gd-elmorietschle.com

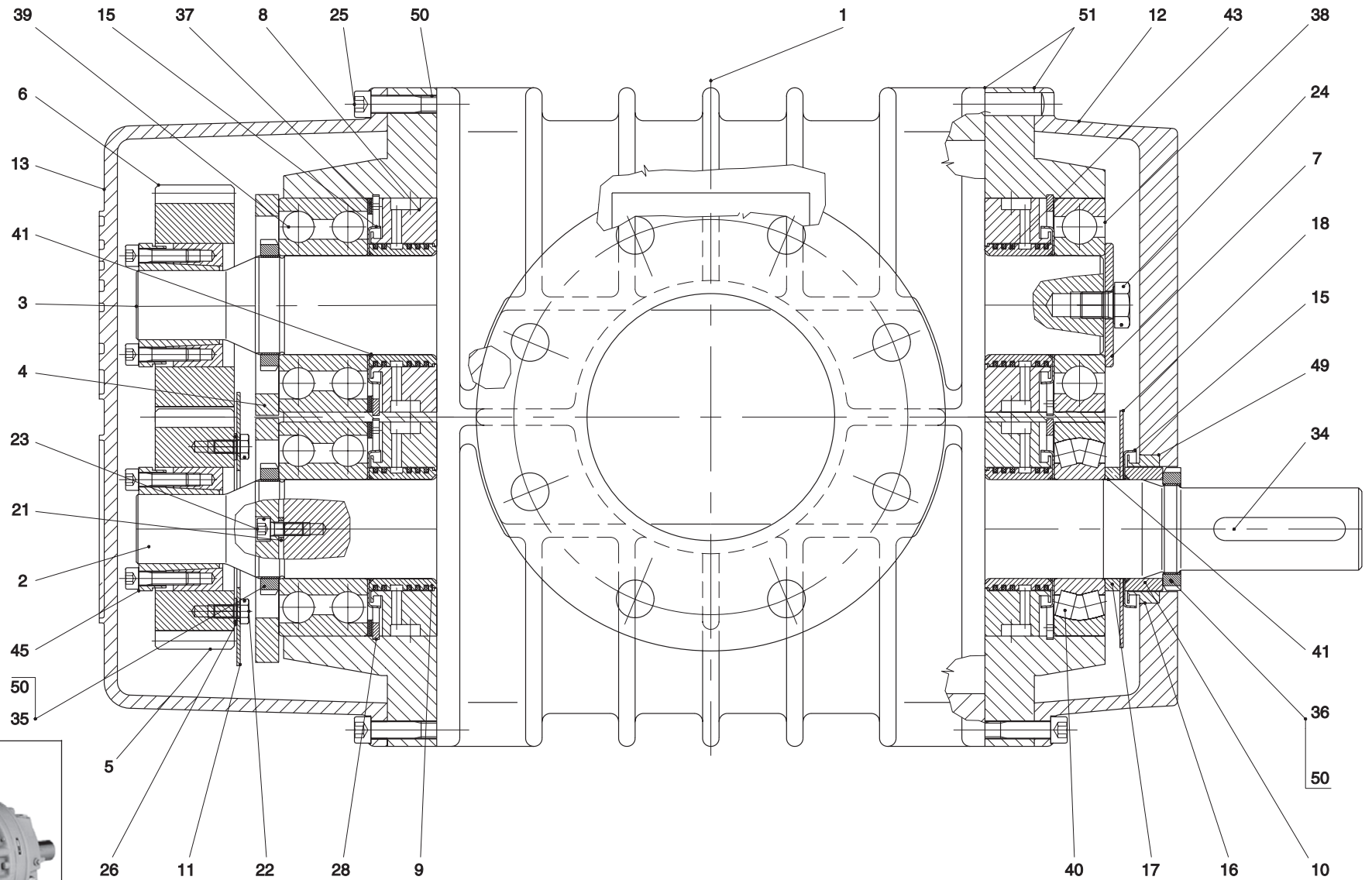

SHARK

WVB (01)

WPB (01)



E 851/5

1.1.2001

	Grundteile	Basic parts	Elément de base	Parti fondamentali			Key	Clavette	Chiavetta
1	Gehäuse	Housing	Corps	Corpo pompa	34	Passfeder 14 x 9 x 80	Key	Clavette	Chiavetta
2	Drehkolben 'A	Rotary piston 'A	Piston rotatif 'A	Pistone rotante 'A	35	Nutmutter KM 12	Groove nut	Ecrou mortaise	Dado cilindrico ad intagli
3	Drehkolben 'B	Rotary piston 'B	Piston rotatif 'B	Pistone rotante 'B	36	Nutmutter KM 11	Groove nut	Ecrou mortaise	Dado cilindrico ad intagli
4	Lagerdeckel	Bearing cover	Couvercle palier	Coperchio cuscinetti	37	Federscheibe 129,5 x 110,5 x 0,8	Spring shim	Rondelle ressort	Disco a molla
5	Zahnrad 'treibend	Gear wheel 'driving	Roue dentée	Ruota dentata trainante	38 V	Rillenkugellager	Deep groove ball bearing	Roulement aiguille	Cuscinetto a sfera
6	Zahnrad 'getrieben	Gear wheel 'driven	Roue dentée	Ruota dentata trainata	39 V	Zweireih. Rillenkugellager	Deep groove ball bearing	Roulement aiguille	Cuscinetto a sfera
7	Scheibe	Disc	Rondelle	Disco	40 V	Pendelkugellager	Self-aligning ball-bearing	Roulement à billes articulé	Cuscinetto a sfere
8	Abdichtung 'B	Seal 'B	Étanchéité 'B	Otturazione 'B	41 D	O-Ring 60 x 2	O-Ring	Joint torique	O-Ring
9	Buchse	Sleeve	Douille	Bussola	43 V	Kolbenring	Piston ring	Bague de piston	Anello pistone
10	Buchse 'A	Sleeve 'A	Douille 'A	Bussola 'A	44 V	Ölschauglas	Oil sight glass	Voyant d'huile	Spia verifica
11	Schleuderscheibe 'B	Flinger 'B	Disque centrifuge 'B	Disco centrifugo 'B	45	Konus-Spannelement TLK 130	Conical-clamping element	Élément tendeur étoupe	Elemento di serraggio cavo
12	Deckel 'A	Cover 'A	Couvercle 'A	Coperchio 'A	49	Loctite-Schraubensicherung	Screw protection	Protection vis	Protezione di viti
13	Deckel 'B	Cover 'B	Couvercle 'B	Coperchio 'B	50	Loctite-Schraubensicherung	Screw protection	Protection vis	Protezione di viti
15	Spritzscheibe	Splash disc	Disque pulvérisateur	Disco spruzzatore	51	Loctite-Schraubensicherung	Screw protection	Protection vis	Protezione di viti
16	Gleitring	Sliding ring	Bague de lubrification	Anello di scorrimento					
17	Distanzring	Spacer ring	Rondelle entretoise	Anello distanziatore					
18	Schleuderscheibe 'A	Flinger 'A	Disque centrifuge 'A	Disco centrifugo 'A					
21	Ring	Ring	Anneau	Anello					
22	Sechskantschraube M 8 x 16	Hexagon head screw	Vis six pans	Vite con testa esagonale					
23	Innen-Sechskantschraube M 8 x 20	Allen screw	Vis 6 pans creuse	Vite a brugola esagonale					
24	Sechskantschraube M 16 x 20	Hexagon head screw	Vis six pans	Vite con testa esagonale					
25	Innen-Sechskantschraube M 10 x 60	Allen screw	Vis 6 pans creuse	Vite a brugola esagonale					
26	Scheibe	Disc	Rondelle	Disco					
28	Sicherungsring	Lock ring	Circlip	Anello di sicurezza					
29 D	Dichtring 10 x 14 x 1	Sealing ring	Anneau d'étanchéité	Anello di tenuta					
30 D	Dichtring 12 x 16 x 1,5	Sealing ring	Anneau d'étanchéité	Anello di tenuta					
31	Verschluss-Stopfen M 12 x 1,5	Plug	Ecrou obturateur	Tappo					
32	Verschluss-Stopfen M 10 x 1	Plug	Ecrou obturateur	Tappo					

Bei Bestellungen folgendes angeben: Typ, Fabrikations-Nr., Positions-Nr., Motor (kW, V, Hz)

To order please indicate: model, serial-no., item-no., motor (kW, V, Hz)

En cas de commande préciser: type d'appareil, no. de position des pièces, moteur (kW, V, Hz)

Nell'ordine indicare: tipo, numero di matricola, numero di posizione dei ricambi, motore (kW, V, Hz)

V = Verschleißteile

V = Wearing parts

V = Pièces d'usure

V = Parti usurabili

D = Dichtungen

D = Seals

D = Joints

D = Guarnizioni

Gardner Denver Schopfheim GmbH

Postfach 1260 • 79642 SCHOPFHEIM / GERMANY

Fon +49 7622 / 392-0 • Fax +49 7622 / 392-300

er.de@gardnerdenver.com • www.gd-elmorietschle.com

WVB / WPB 3300 (01)

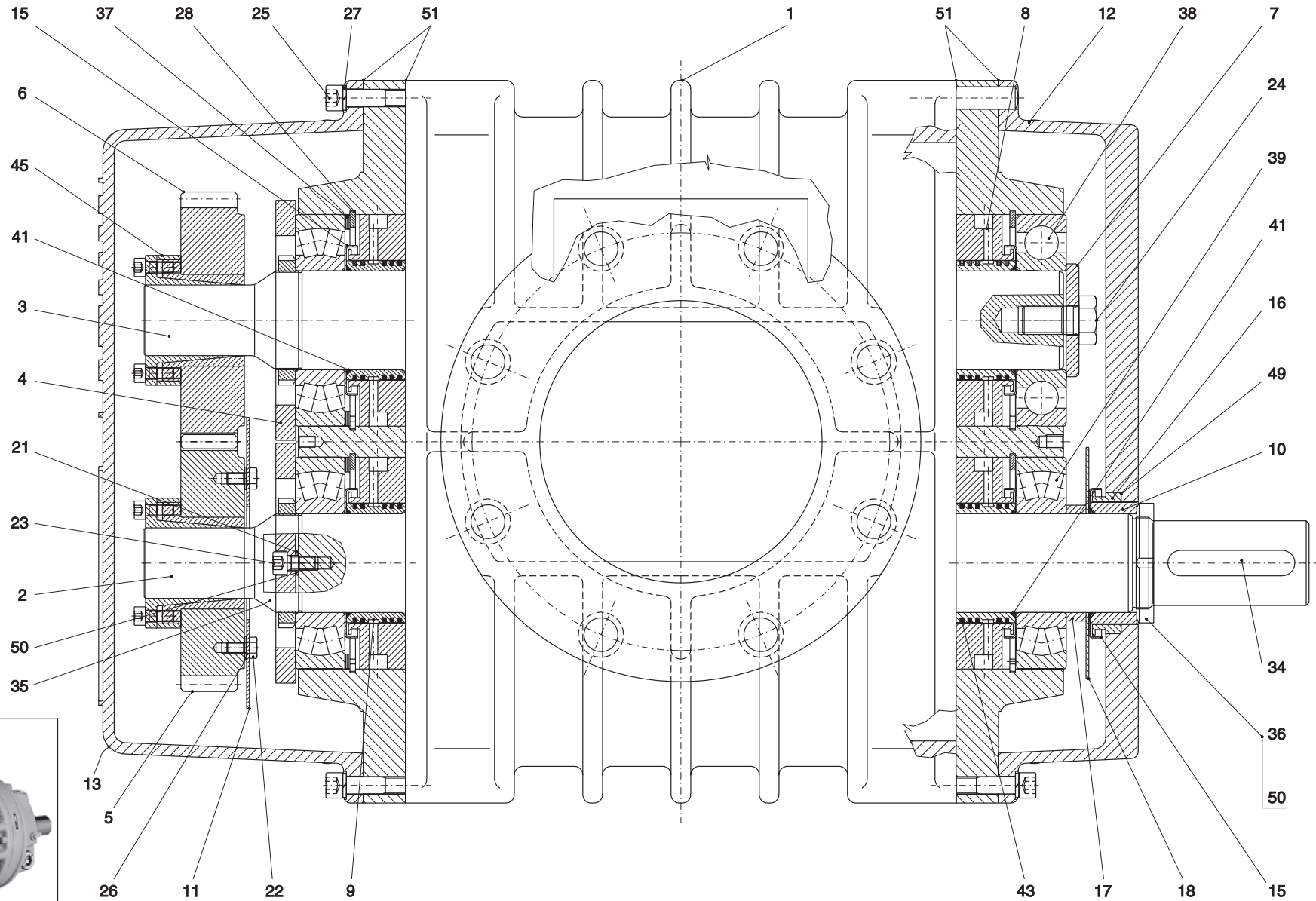

SHARK

WVB (01)

WPB (01)



E 851/6

1.1.2001

	Grundteile	Basic parts	Élément de base	Parti fondamentali					
1	Gehäuse	Housing	Corps	Corpo pompa	32	Verschluss-Stopfen M 10 x 1	Plug	Ecrou obturateur	Tappo
2	Drehkolben 'A	Rotary piston 'A	Piston rotatif 'A	Pistone rotante 'A	34	Passfeder 18 x 11 x 90	Key	Clavette	Chiavetta
3	Drehkolben 'B	Rotary piston 'B	Piston rotatif 'B	Pistone rotante 'B	35	Nutmutter KM 13	Groove nut	Ecrou mortaise	Dado cilindrico ad intagli
4	Lagerdeckel	Bearing cover	Couvercle palier	Coperchio cuscinetti	37	Federscheibe	Spring shim	Rondelle ressort	Disco a molla
5	Zahnrad 'treibend	Gear wheel 'driving	Roue dentée	Ruota dentata trainante	38 V	Riilenkugellager	Deep groove ball bearing	Roulement aiguille	Cuscinetto a sfera
6	Zahnrad 'getrieben	Gear wheel 'driven	Roue dentée	Ruota dentata trainata	39 V	Pendelkugellager	Self-aligning ball-bearing	Roulement à billes articulé	Cuscinetto a sfera
7	Scheibe	Disc	Rondelle	Disco	41 D	O-Ring 70 x 2	O-Ring	Joint torique	O-Ring
8	Abdichtung 'B	Seal 'B	Étanchéité 'B	Otturazione 'B	43 V	Kolbenring	Piston ring	Bague de piston	Anello pistone
9	Buchse	Sleeve	Douille	Bussola	44 V	Ölschauglas	Oil sight glass	Voyant d'huile	Spia verifica
10	Buchse 'A	Sleeve 'A	Douille 'A	Bussola 'A	45	Konus-Spannelement TLK 110	Conical-clamping element	Élément tendeur étoupe	Elemento di serraggio cavo
11	Schleuderscheibe 'B	Flinger 'B	Disque centrifuge 'B	Disco centrifugo 'B	49	Loctite-Schraubensicherung	Screw protection	Protection vis	Protezione di viti
12	Deckel 'A	Cover 'A	Couvercle 'A	Coperchio 'A	50	Loctite-Schraubensicherung	Screw protection	Protection vis	Protezione di viti
13	Deckel 'B	Cover 'B	Couvercle 'B	Coperchio 'B	51	Loctite-Schraubensicherung	Screw protection	Protection vis	Protezione di viti
15	Spritzscheibe	Splash disc	Disque pulvérisateur	Disco spruzzatore					
16	Gleitring	Sliding ring	Bague de lubrification	Anello di scorrimento					
17	Distanzring	Spacer ring	Rondelle entretoise	Anello distanziatore					
18	Schleuderscheibe 'A	Flinger 'A	Disque centrifuge 'A	Disco centrifugo 'A					
21	Ring	Ring	Anneau	Anello					
22	Sechskantschraube M 8 x 16	Hexagon head screw	Vis six pans	Vite con testa esagonale					
23	Innen-Sechskantschraube M 10 x 25	Allen screw	Vis 6 pans creuse	Vite a brugola esagonale					
24	Sechskantschraube M 20 x 40	Hexagon head screw	Vis six pans	Vite con testa esagonale					
25	Innen-Sechskantschraube M 12 x 60	Allen screw	Vis 6 pans creuse	Vite a brugola esagonale					
26	Scheibe	Disc	Rondelle	Disco					
27	Federring	Spring ring	Anneau ressort	Rosetta elastica					
28	Sicherungsring	Lock ring	Circlip	Anello di sicurezza					
29 D	Dichtring 10 x 14 x 1	Sealing ring	Anneau d'étanchéité	Anello di tenuta					
30 D	Dichtring 12 x 16 x 1,5	Sealing ring	Anneau d'étanchéité	Anello di tenuta					
31	Verschluss-Stopfen M 12 x 1,5	Plug	Ecrou obturateur	Tappo					

Bei Bestellungen folgendes angeben: Typ, Fabrikations-Nr., Positions-Nr., Motor (kW, V, Hz)

To order please indicate: model, serial-no., item-no., motor (kW, V, Hz)

En cas de commande préciser: type d'appareil, no. de position des pièces, moteur (kW, V, Hz)

Nell'ordine indicare: tipo, numero di matricola, numero di posizione dei ricambi, motore (kW, V, Hz)

V = Verschleißteile

V = Wearing parts

V = Pièces d'usure

V = Parti usurabili

D = Dichtungen

D = Seals

D = Joints

D = Guarnizioni

Gardner Denver Schopfheim GmbH

Postfach 1260 • 79642 SCHOPFHEIM / GERMANY

Fon +49 7622 / 392-0 • Fax +49 7622 / 392-300

er.de@gardnerdenver.com • www.gd-elmorietschle.com

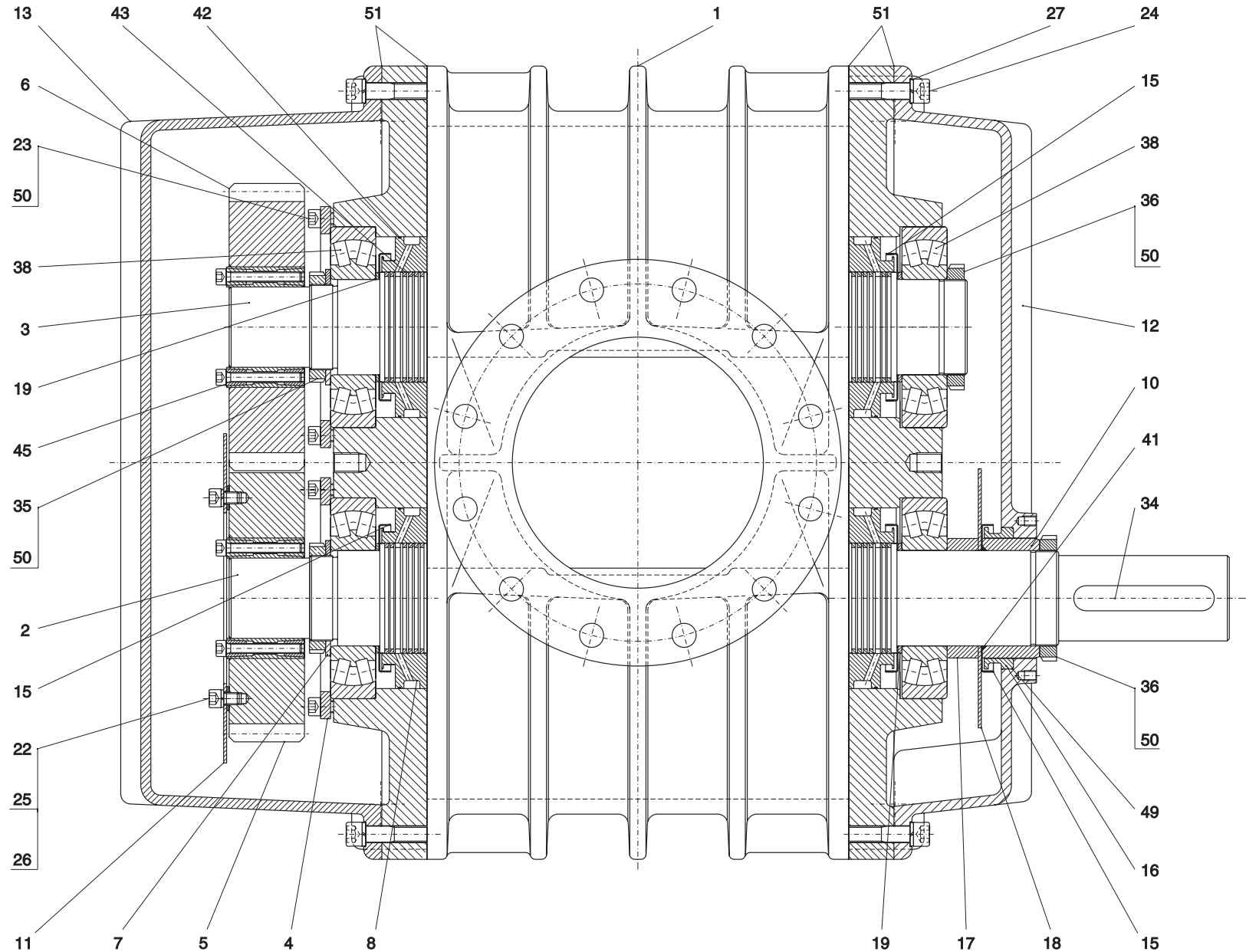

SHARK

WVB (01)

WPB (01)



E 851/7

1.1.2001

	Grundteile	Basic parts	Élément de base	Parti fondamentali					
1	Gehäuse	Housing	Corps	Corpo pompa	33	Ringschraube	Lifting eye	Anneau de levage	Golfare
2	Drehkolben 'A	Rotary piston 'A	Piston rotatif 'A	Pistone rotante 'A	34	Passfeder 25 x 14 x 140	Key	Clavette	Chiavetta
3	Drehkolben 'B	Rotary piston 'B	Piston rotatif 'B	Pistone rotante 'B	35	Nutmutter KM 17	Groove nut	Ecrou mortaise	Dado cilindrico ad intagli
4	Lagerdeckel	Bearing cover	Couvercle palier	Coperchio cuscinetti	36	Nutmutter KM 19	Groove nut	Ecrou mortaise	Dado cilindrico ad intagli
5	Zahnrad 'treibend	Gear wheel 'driving	Roue dentée	Ruota dentata trainante	38 V	Pendelkugellager	Self-aligning ball-bearing	Roulement à billes articulé	Cuscinetto a sfere
6	Zahnrad 'getrieben	Gear wheel 'driven	Roue dentée	Ruota dentata trainata	41 D	O-Ring 60 x 2	O-Ring	Joint torique	O-Ring
7	Scheibe	Disc	Rondelle	Disco	42 D	O-Ring 175 x 2	O-Ring	Joint torique	O-Ring
8	Abdichtung 'B	Seal 'B	Étanchéité 'B	Otturazione 'B	43 V	Kolbenring	Piston ring	Bague de piston	Anello pistone
9	Buchse	Sleeve	Douille	Bussola	44 V	Ölschauglas	Oil sight glass	Voyant d'huile	Spia verifica
10	Buchse 'A	Sleeve 'A	Douille 'A	Bussola 'A	45	Konus-Spannelement TLK 400	Conical-clamping element	Élément tendeur étoupe	Elemento di serraggio cavo
11	Schleuderscheibe 'B	Flinger 'B	Disque centrifuge 'B	Disco centrifugo 'B	49	Loctite-Schraubensicherung	Screw protection	Protection vis	Protezione di viti
12	Deckel 'A	Cover 'A	Couvercle 'A	Coperchio 'A	50	Loctite-Schraubensicherung	Screw protection	Protection vis	Protezione di viti
13	Deckel 'B	Cover 'B	Couvercle 'B	Coperchio 'B	51	Loctite-Schraubensicherung	Screw protection	Protection vis	Protezione di viti
15	Spritzscheibe	Splash disc	Disque pulvérisateur	Disco spruzzatore					
16	Gleitring	Sliding ring	Bague de lubrification	Anello di scorrimento					
17	Distanzring	Spacer ring	Rondelle entretoise	Anello distanziatore					
18	Schleuderscheibe 'A	Flinger 'A	Disque centrifuge 'A	Disco centrifugo 'A					
19	Ring	Ring	Anneau	Anello					
22	Innen-Sechskantschraube M 12 x 16	Allen screw	Vis 6 pans creuse	Vite a brugola esagonale					
23	Innen-Sechskantschraube M 12 x 30	Allen screw	Vis 6 pans creuse	Vite a brugola esagonale					
24	Innen-Sechskantschraube M 16 x 90	Allen screw	Vis 6 pans creuse	Vite a brugola esagonale					
25	Scheibe	Disc	Rondelle	Disco					
26	Federring	Spring ring	Anneau ressort	Rosetta elastica					
27	Federring	Spring ring	Anneau ressort	Rosetta elastica					
29 D	Dichtring 10 x 14 x 1	Sealing ring	Anneau d'étanchéité	Anello di tenuta					
30 D	Dichtring 24 x 30 x 1,5	Sealing ring	Anneau d'étanchéité	Anello di tenuta					
31	Verschluss-Stopfen M 24 x 1,5	Plug	Ecrou obturateur	Tappo					
32	Verschluss-Stopfen M 10 x 1	Plug	Ecrou obturateur	Tappo					

Bei Bestellungen folgendes angeben: Typ, Fabrikations-Nr., Positions-Nr., Motor (kW, V, Hz)

To order please indicate: model, serial-no., item-no., motor (kW, V, Hz)

En cas de commande préciser: type d'appareil, no. de position des pièces, moteur (kW, V, Hz)

Nell'ordine indicare: tipo, numero di matricola, numero di posizione dei ricambi, motore (kW, V, Hz)

V = Verschleißteile

V = Wearing parts

V = Pièces d'usure

V = Parti usurabili

D = Dichtungen

D = Seals

D = Joints

D = Guarnizioni

Gardner Denver Schopfheim GmbH

Postfach 1260 • 79642 SCHOPFHEIM / GERMANY

Fon +49 7622 / 392-0 • Fax +49 7622 / 392-300

er.de@gardnerdenver.com • www.gd-elmorietschle.com