

Data sheet liquidring pump

Series L-BV2

| L_200

Range 2BV2 071 Vacuum pump with gas ejector

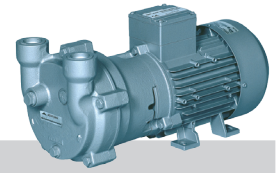

Performance curves for vacuum operation

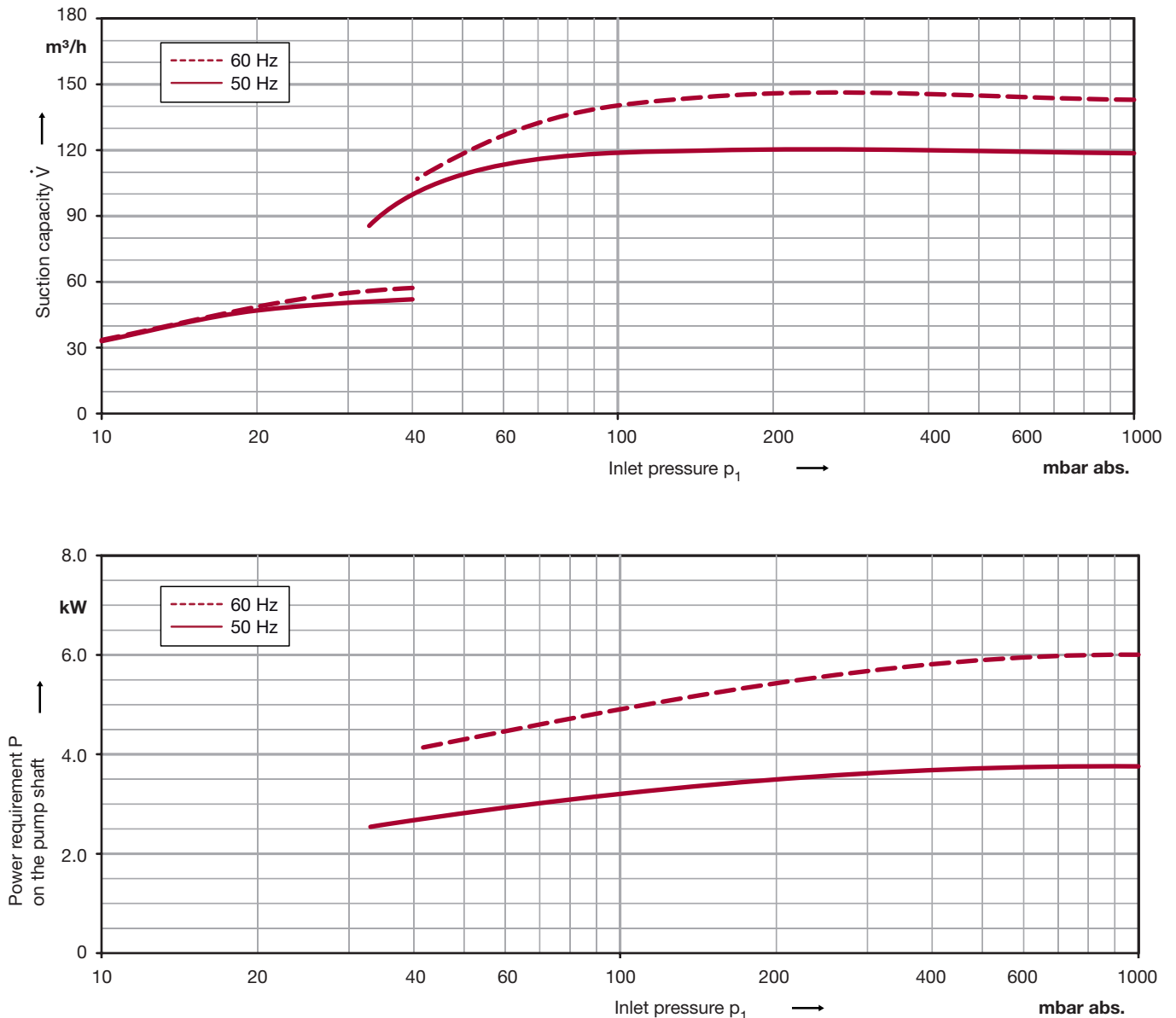

Vacuum pumps of the L-BV2 range are suitable for evacuating gases and wet vapours down to inlet pressures of 33 mbar abs. (97% vacuum). All these vacuum pumps are equipped with built-in cavitation protection. For operation below 80 mbar abs. the cavitation protection should be connected to protect the vacuum pump. All pumps L-BV2 are especially space-saving in their monoblock design. They are available in cast iron (standard color RAL 9006). The motor is painted as standard in RAL 9006.

The motors are supplied as standard for the input voltage ranges of 50 and 60 Hz and for the protection category IP55 as well as approved for UL and CSA. Vacuum pumps with ATEX 94/9 EG for category 2G are available, too. The characteristics are valid for the inlet of air with a relative humidity of 100 % and a temperature of 20 °C, compression to 1013 mbar abs. and water at 15 °C as operating liquid. The tolerance is ± 10 %.

Selection and ordering data

Materials	Motor data				Service-factor	Order-No.	Quantity of operating liquid	Sound pressure level **	Weight approx.		
	Fre-quency	Rated									
		voltage	current	output							
Casing/port plate/impeller	Hz	V	A	kW	SF	m³/h	dB(A)	kg			
3- 50/60 Hz version, protection class IP 55, insulation class F *											
cast iron/ceramic/bronze	50 60	200Δ...240Δ 220Δ...275Δ	345Y...415Y 380Y...480Y	20.8 20.8	12.0 12.0	3.85 6.3	1.4 1.0	2BV2071-0NH04-8S	0.45 0.45	72 76	55
cast iron/ceramic/bronze	50 60	500Δ 575Δ		10.0 10.0		3.85 6.3	1.4 1.0	2BV2071-0NH04-5S	0.45 0.45	72 76	55
CrNi steel/ceramic/CrNi steel	50 60	200Δ...240Δ 220Δ...275Δ	345Y...415Y 380Y...480Y	20.8 20.8	12.0 12.0	3.85 6.3	1.4 1.0	2BV2071-0PH04-8S	0.45 0.45	72 76	55
CrNi steel/ceramic/CrNi steel	50 60	500Δ 575Δ		10.0 10.0		3.85 6.3	1.4 1.0	2BV2071-0PH04-5S	0.45 0.45	72 76	55
CrNi steel/CrNi steel/CrNi steel	50 60	200Δ...240Δ 220Δ...275Δ	345Y...415Y 380Y...480Y	20.8 20.8	12.0 12.0	3.85 6.3	1.4 1.0	2BV2071-0HH04-8S	0.45 0.45	72 76	55
CrNi steel/CrNi steel/CrNi steel	50 60	500Δ 575Δ		10.0 10.0		3.85 6.3	1.4 1.0	2BV2071-0HH04-5S	0.45 0.45	72 76	55
Gas ejector (for connecting in front of the vacuum pump)											
Heat/Difusor/Jet	Material name			Frequency	for vacuum pump						
cast iron/brass/brass	GG 20 / MS 58 / MS 58			50 / 60 Hz	2BV2 071-0N...		2BP1071-1N		4		
CrNi steel/CrNi steel/CrNi steel	G-X7CrNiMoNb 1810 / X10CrNiMoTi 1810 / X10CrNiMoTi 1810			50 / 60 Hz	2BV2 071-0H... 2BV2 071-0P...		2BP1071-1H		4		

The motors are designed according to DIN EN 60 034 / DIN IEC 34-1 and temperature class F. For the three phase machines the tolerances are ± 10 % for fixed voltage and ± 5 % for voltage range.

For all three phase machines according to UL and CSA norm (UL 507 and CSA 22.2 No. 100) the maximum allowed voltage tolerances are -10 % resp. +6 %. The frequency tolerance is maximum ± 2 %.

All L-BV2 achieve the standards and norms of the low voltage directive 72/23/EWG, rotating electrotechnical motor EN 60034-1-34, electromagnetic compatibility (EMC) DIN EN 61000-0/-6/-4.

* For standard UL 507 and CSA 22.2 No 113 (Certificate Number E225239).

** Measuring-surface sound-pressure level acc. to DIN EN 21680, measured at a distance of 1 m at medium inlet pressure and with connected pipes.

*** The quantities of operating liquid apply for fresh water operation without discharge liquid separator.

For partial recirculation operation the quantity of the fresh applied refrigerant can be reduced by circulation of the operating liquid in a circuit (with discharge liquid separator and internal recirculation of the operating liquid, available as accessories).

An inlet pressure of 10 mbar abs. can be achieved by connecting a gas ejector (see accessories). The gas ejector can be mounted directly onto the vacuum pump.

Other voltages

		2BV2 071-... □ - □ S	
50 Hz	60 Hz		
3-			
185...220 V Δ / 320...380 V Y 220...240 V Δ / 345...415 V Y 345...415 V Δ 500 V Δ	200...254 V Δ / 345...440 V Y 220...275 V Δ / 380...480 V Y 380...480 V Δ 575 V Δ	H H H H	0 8 7 5
3- ATEX Category 2G			
230 V Δ / 400 V Y 400 V Δ / 690 V Y 500 V Δ	- - -	D D D	1 6 5

Quantity of Operating Liquid

Frequency	for fresh water operation / partial recirculation Inlet pressure p (abs.) ***		
	< 200 mbar	200 - 500 mbar	> 500 mbar
Hz	m³/h		m³/h
50	0.45 / 0.25		0.45 / 0.25
60	0.45 / 0.25		0.45 / 0.25

Max. add. water carry-over or permissible back pressure

Frequency	max. additional water carry-over	max. permissible back pressure
Hz	m³/h	mbar abs.
50	1.12	1200
60	1.12	1200

Dimensions

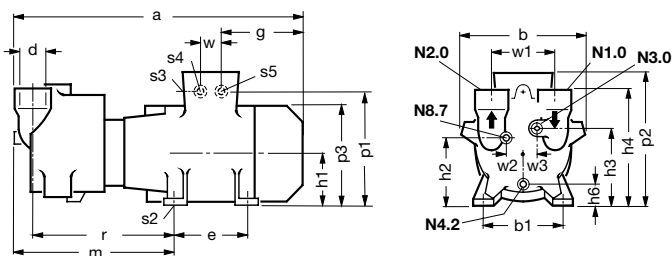

- N1.0 Inlet flange
- N2.0 Pressure flange
- N3.0 Connection operating liquid
- N4.2 Drain
- N8.7 Cavitation protection

2BV2 071-....4-..	a	b	b1	e	g	h1	h2	h3	h4	h6	m	p1	p2	p3	r
[mm]	558	266	203	180	224	133	160	178	254	65	278	240	300	265	240
	s2	s3/s4		s5		w	w1	w2	w3	d (N1.0, N2.0)	N3.0	N4.2	N8.7		
	14	M32 x 1,5		M32 x 1,5		42	110	33	27	G1½ x 22	G¾ x 12	G¼ x 12	G¾ x 12		

Exploded drawing

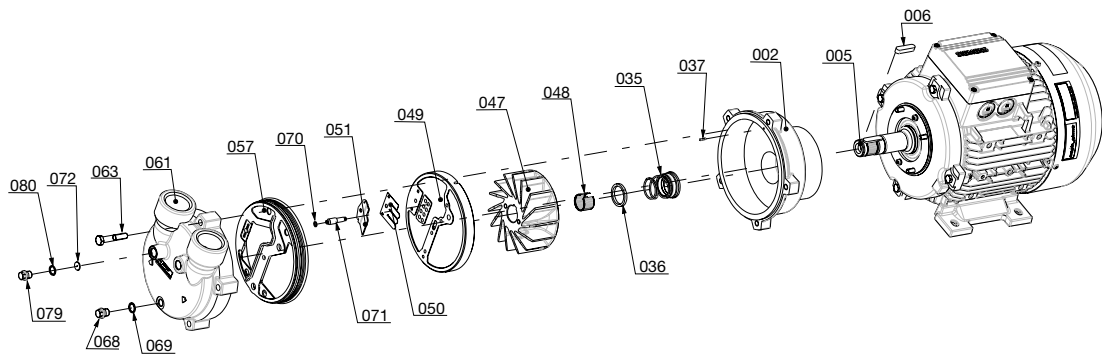

Materials of construction

Part-No.	Designation	Material combination		
		cast iron/ceramic/bronze	CrNi steel/ceramic/CrNi steel	CrNi steel/CrNi steel/CrNi steel
002	Casing	Grey cast iron (EN-GJL HB 195 / EN-JL2030) EN 1561	Cast chrome-nickel-molybdenum steel (G-X6CrNiMo 18-10 / 1.4408) EN 10213-4	Cast chrome-nickel-molybdenum steel (G-X6CrNiMo 18-10 / 1.4408) EN 10213-4
005	Pump shaft	Chrome steel (X20Cr13 / 1.4021) EN 10088 - 3	Chrome-nickel-molybdenum steel (X6CrNiMoTi 17-12-2 / 1.4571) EN 10088 - 3	Chrome-nickel-molybdenum steel (X6CrNiMoTi 17-12-2 / 1.4571) EN 10088 - 3
006	Feather key	Chrome-nickel-molybdenum steel (X6CrNiMoTi 17-12-2 / 1.4571) EN 10088 - 3	Chrome-nickel-molybdenum steel (X6CrNiMoTi 17-12-2 / 1.4571) EN 10088 - 3	Chrome-nickel-molybdenum steel (X6CrNiMoTi 17-12-2 / 1.4571) EN 10088 - 3
035	Mechanical seal	Carbon / Ceramic / Viton (FPM) / Chrome-nickel steel (EN 12756 - BVVGG)	SIC / Carbon / Viton (FPM) / Teflon (PTFE) sheathed / Chrome-nickel-molybdenum steel (EN 12756 - Q1BM1GG)	SIC / Carbon / Viton (FPM) / Teflon (PTFE) sheathed / Chrome-nickel-molybdenum steel (EN 12756 - Q1BM1GG)
036	Washer	Chrome-nickel steel X10CrNiS 18-9 / 1.4305 / EN 10088 - 3	Chrome-nickel steel X10CrNiS 18-9 / 1.4305 / EN 10088 - 3	Chrome-nickel steel X10CrNiS 18-9 / 1.4305 / EN 10088 - 3
037	Set screw	Chrome-nickel-molybdenum steel (X5CrNiMo 17-12-2 / 1.4401) EN 10088 - 2	Chrome-nickel-molybdenum steel (X5CrNiMo 17-12-2 / 1.4401) EN 10088 - 2	not applicable
047	Impeller	Cast aluminium bronze (G-CuAl10Fe5Ni5 / CC33G-GS) EN 1982	Cast chrome-nickel-molybdenum steel (G-X6CrNiMo 18-10 / 1.4408) EN 10213-4	Cast chrome-nickel-molybdenum steel (G-X6CrNiMo 18-10 / 1.4408) EN 10213-4
048	Tolerance ring for impeller	Chrome-nickel steel (X12CrNi 17-7 / 1.4310) EN 10088 - 2	Chrome-nickel steel (X12CrNi 17-7 / 1.4310) EN 10088 - 2	Chrome-nickel steel (X12CrNi 17-7 / 1.4310) EN 10088 - 2
049	Port plate	Ceramic - C221 EN 60672 - 1	Ceramic - C221 EN 60672 - 1	Cast chrome-nickel-molybdenum steel (G-X6CrNiMo 18-10 / 1.44.08) EN 10213-4
050	Valve plate	Teflon (PTFE)	Teflon (PTFE)	Teflon (PTFE)
051	Intercepting plate	Chrome-nickel-molybdenum steel (X10CrNiMoTi 18-10 / 1.4571) EN 10088 - 2	Chrome-nickel-molybdenum steel (X10CrNiMoTi 18-10 / 1.4571) EN 10088 - 2	Chrome-nickel-molybdenum steel (X10CrNiMoTi 18-10 / 1.4571) EN 10088 - 2
057	Gasket for cover	Nitrile-butadiene-caotchouc (NBR) ISO 1629	Viton (FPM)	flat gasket: Teflon (PTFE) and O-ring: silicone-caotchouc / Teflon (PTFE) sheathed
061	Cover	Grey cast iron (EN-GJL HB 195 / EN-JL2030) EN1561	Cast chrome-nickel-molybdenum steel (G-X6CrNiMo 18-10 / 1.4408) EN 10213-4	Cast chrome-nickel-molybdenum steel (G-X6CrNiMo 18-10 / 1.4408) EN 10213-4
063	Screw	Steel (DIN ISO 8992)	Steel (DIN ISO 8992)	Steel (DIN ISO 8992)
068	Plug screw	Machining steel, lead alloyed (11SMnPb30 / 1.0718) EN 10087	Chrome-nickel-molybdenum steel (X10CrNiMoTi 18-10 / 1.4571) EN 10088 - 3	Chrome-nickel-molybdenum steel (X10CrNiMoTi 18-10 / 1.4571) EN 10088 - 3
069	Sealing ring	Teflon (PTFE)	Teflon (PTFE)	Teflon (PTFE)
070	O-Ring	FPM (flour rubber)	FPM (flour rubber)	FEP (Perfluorethylenpropylen) & Silicon
071	Pipe of cavitation protection	Chrome-nickel-molybdenum steel (X10CrNiMoTi 18-10 / 1.4571) EN 10088 - 3	Chrome-nickel-molybdenum steel (X10CrNiMoTi 18-10 / 1.4571) EN 10088 - 3	Chrome-nickel-molybdenum steel (X10CrNiMoTi 18-10 / 1.4571) EN 10088 - 3
072	Washer for cavitation protection	Chrome-nickel steel (X5CrNi 18-10 / 1.4301) EN 10088 - 3	Chrome-nickel steel (X5CrNi 18-10 / 1.4301) EN 10088 - 3	Chrome-nickel steel (X5CrNi 18-10 / 1.4301) EN 10088 - 3
079	Plug screw	Machining steel, lead alloyed (11SMnPb30 / 1.0718) EN 10087	Chrome-nickel-molybdenum steel (X5CrNiMo 17-12-2 / 1.4401) EN 10088 - 3	Chrome-nickel-molybdenum steel (X5CrNiMo 17-12-2 / 1.4401) EN 10088 - 3
080	Dichtring	Teflon (PTFE)	Teflon (PTFE)	Teflon (PTFE)



Changes in particular the quoted performance curve, datas and weights without prior notice. The figures are without obligations.

Gardner Denver

*Elmo Rietschle is a brand of the
Gardner Denver Blower Division*

info@de.gardnerdenver.com
www.gd-elmorietschle.com

Gardner Denver Schopfheim GmbH

Roggenbachstraße 58
79650 Schopfheim - Germany

Tel.: +49 7622 392-0
Fax: +49 7622 392-300

Gardner Denver Deutschland GmbH

Industriestraße 26
97616 Bad Neustadt - Germany

Tel.: +49 9771 6888-0
Fax: +49 9771 6888-4000