

Data sheet liquidring pump

Series L-BV2 | L_200
Range 2BV2 061 Compressor

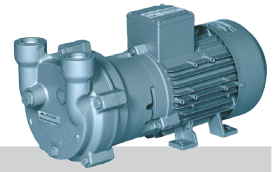

Performance curves for compressor operation

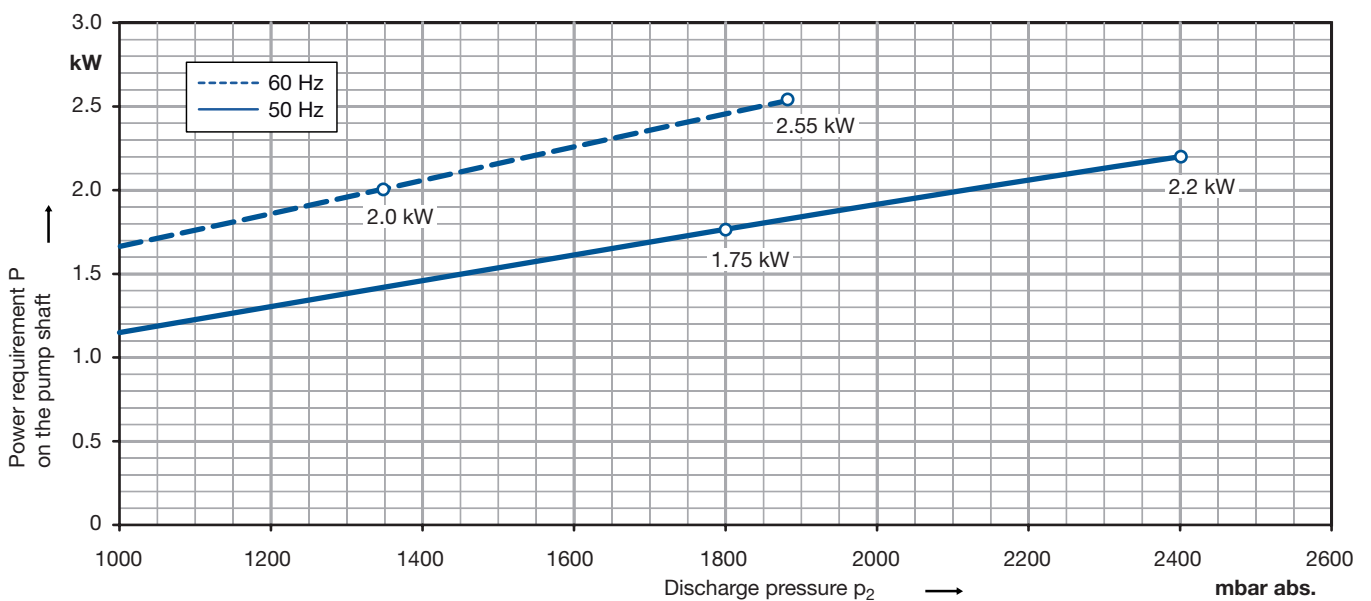
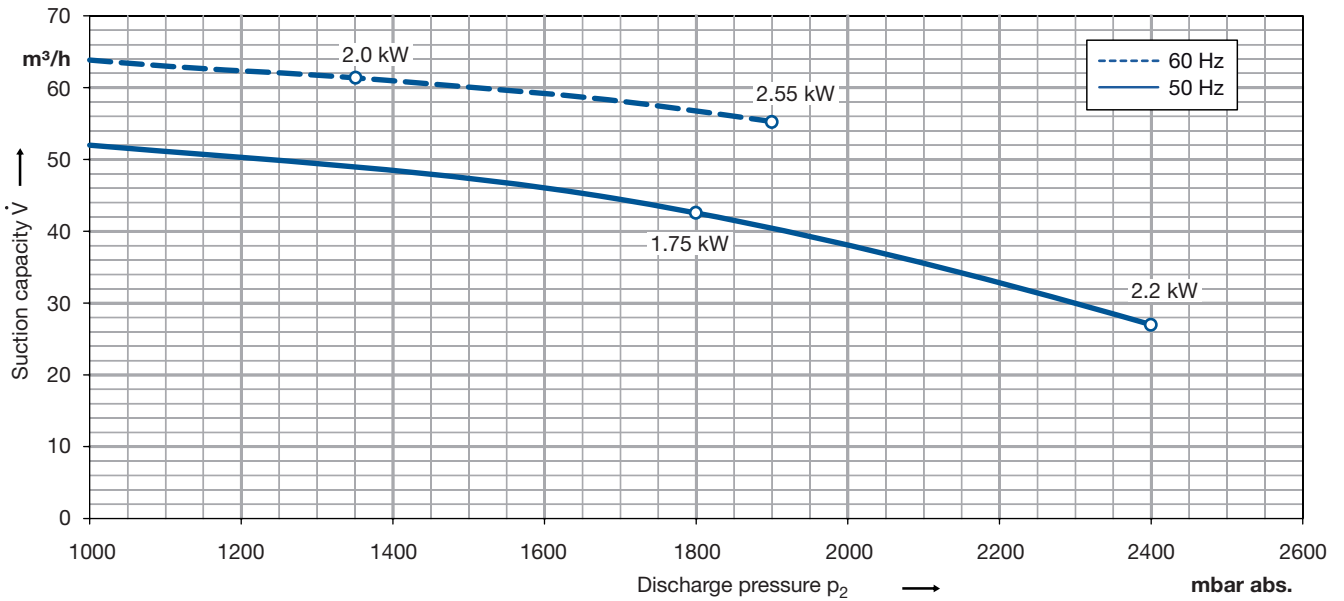

The characteristics are valid for the inlet of air with a relative humidity of 50 % and a temperature of 20 °C at a atmospheric pressure of 1013 mbar abs. and water at 15 °C as operating liquid.
The tolerance is $\pm 10\%$.

The motors are supplied as standard for the input voltage ranges of 50 and 60 Hz and for the protection category IP55 as well as approbated for UL and CSA. Compressors with ATEX 94/9 EG for category 2G are available, too.

Selection and ordering data

| Materials Casing/port plate/impeller | Motor data | | | | | | Order-No. | Quantity of operating liquid m³/h | Sound pressure level ** dB(A) | Weight approx. kg |
|--|----------------------|----------------------------|----------------------------|--------------|------------|---------------------------|-------------------------|--------------------------------------|----------------------------------|----------------------|
| | Fre- quency Hz | Rated | | | | | | | | |
| | | voltage V | current A | output kW | | | | | | |
| 3- 50/60 Hz version, protection class IP 55, insulation class F * | | | | | | | | | | |
| cast iron/ceramic/bronze | 50 60 | 200Δ...240Δ 220Δ...275Δ | 345Y...415Y 380Y...480Y | 5.9 7.8 | 3.4 4.5 | 1.75 2.0 | 2BV2061-8NH03-8S | 0.25 0.25 | 70 72 | 25 |
| cast iron/ceramic/bronze | 50 60 | 345Δ...415Δ 380Δ...480Δ | | 3.4 4.5 | | 1.75 2.0 | 2BV2061-8NH03-7S | 0.25 0.25 | 70 72 | 25 |
| cast iron/ceramic/bronze | 50 60 | 500Δ 575Δ | | 4.5 4.55 | | 2.2 2.55 | 2BV2061-8NH03-5S | 0.25 0.25 | 70 72 | 25 |
| CrNi steel/ceramic/CrNi steel | 50 60 | 200Δ...240Δ 220Δ...275Δ | 345Y...415Y 380Y...480Y | 5.9 7.8 | 3.4 4.5 | 1.75 2.0 | 2BV2061-8MH03-8S | 0.25 0.25 | 70 72 | 25 |
| CrNi steel/ceramic/CrNi steel | 50 60 | 345Δ...415Δ 380Δ...480Δ | | 3.4 4.5 | | 1.75 2.0 | 2BV2061-8MH03-7S | 0.25 0.25 | 70 72 | 25 |
| CrNi steel/ceramic/CrNi steel | 50 60 | 500Δ 575Δ | | 4.5 4.55 | | 2.2 2.55 | 2BV2061-8MH03-5S | 0.25 0.25 | 70 72 | 25 |

The motors are designed according to DIN EN 60 034 / DIN IEC 34-1 and temperature class F. For the three phase machines the tolerances are ± 10 % for fixed voltage and ± 5 % for voltage range.

For all three phase machines according to UL and CSA norm (UL 507 and CSA 22.2 No. 100) the maximum allowed voltage tolerances are -10 % resp. +6 %. The frequency tolerance is maximum ± 2 %.

All **L-BV2** achieve the standards and norms of the low voltage directive 72/23/EWG, rotating electrotechnical motor EN 60034-1-34, electromagnetic compatibility (EMC) DIN EN 61000-0/-6/-4.

* For standard UL 507 and CSA 22.2 No 113 (Certificate Number E225239).

** Measuring-surface sound-pressure level acc. to DIN EN 21680, measured at a distance of 1 m at medium inlet pressure and with connected pipes.

*** The quantities of operating liquid apply for fresh water operation without discharge liquid separator.

For partial recirculation operation the quantity of the fresh applied refrigerant can be reduced by circulation of the operating liquid in a circuit (with discharge liquid separator and internal recirculation of the operating liquid, available as accessories).

Other voltages

| 2BV2 061-... □ - □ S | | | | |
|--|--|--|------------------|------------------|
| 50 Hz | 60 Hz | | | |
| 3- | | | | |
| 185...220 V Δ / 320...380 V Y 220...240 V Δ / 345...415 V Y 345...415 V Δ 500 V Δ | 200...254 V Δ / 345...440 V Y 220...275 V Δ / 380...480 V Y 380...480 V Δ 575 V Δ | | H H H H | 0 8 7 5 |
| 3- ATEX Category 2G | | | | |
| 230 V Δ / 400 V Y 400 V Δ / 690 V Y 500 V Δ | - - - | | D D D | 1 6 5 |
| - - - | 460 V Δ 460 V Y 575 V Δ | | G G G | 6 1 5 |

Quantity of Operating Liquid

| Frequency | for fresh water operation at Inlet pressure *** |
|-----------|--|
| Hz | m³/h |
| 50 | 0.25 |
| 60 | 0.25 |

Dimensions

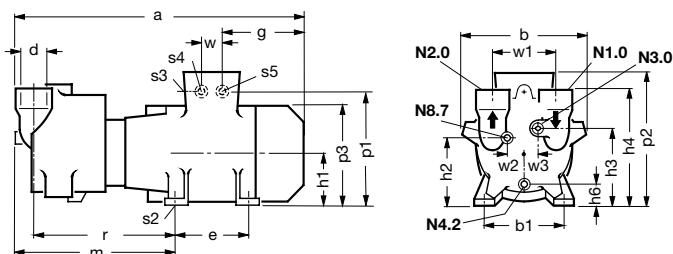

N1.0 Inlet flange
N2.0 Pressure flange
N3.0 Connection operating liquid
N4.2 Drain
N8.7 Cavitation protection

| 2BV2 061-...3- | a | b | b1 | e | g | h1 | h2 | h3 | h4 | h6 | m | p1 | p2 | p3 | r |
|----------------|-----|-----------|-----|-----------|-----|-----|-----|-----|----------------|---------|---------|---------|-----|-----|-----|
| [mm] | 475 | 181 | 140 | 100 | 184 | 90 | 118 | 126 | 195 | 37 | 253 | 195 | 218 | 180 | 226 |
| | s2 | s3/s4 | | s5 | w | w1 | w2 | w3 | d (N1.0, N2.0) | N3.0 | N4.2 | N8.7 | | | |
| | 10 | M25 x 1.5 | | M16 x 1.5 | 32 | 110 | 25 | 21 | G1 x 20 | G¾ x 12 | G¼ x 12 | G¾ x 12 | | | |

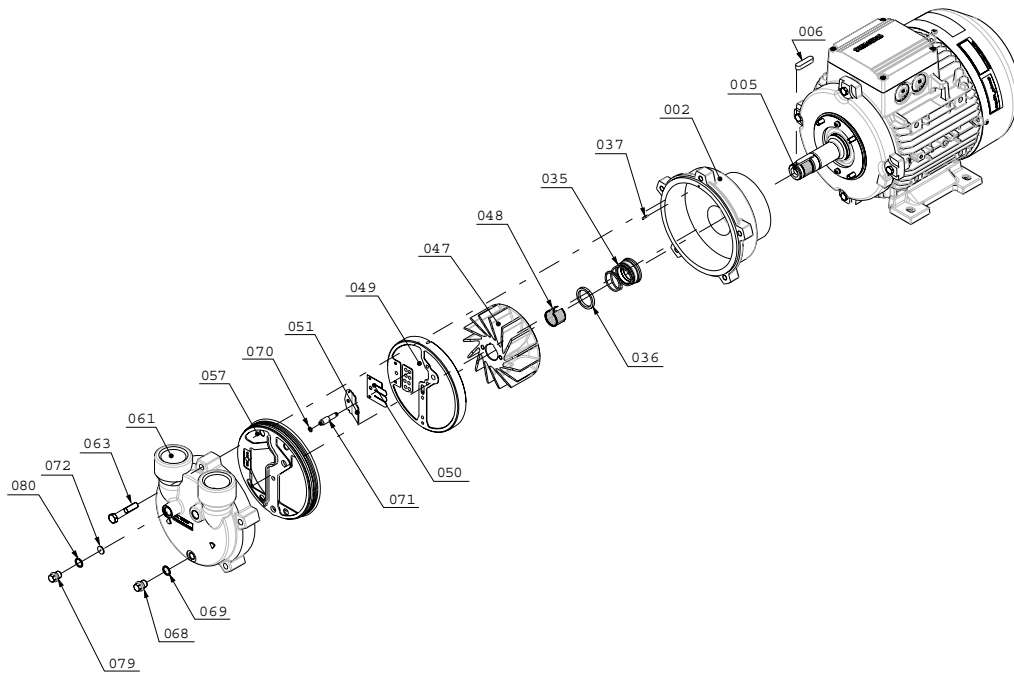

Materials of construction

| Part-Nr. | Designation | Material combination | |
|----------|----------------------------------|---|--|
| | | cast iron/ceramic/bronze | CrNi steel/ceramic/CrNi steel |
| 002 | Casing | Grey cast iron (EN-GJL HB 195 / EN-JL2030) EN 1561 | Cast chrome-nickel-molybdenum steel (G-X6CrNiMo 18-10 / 1.4408) EN 10213-4 |
| 005 | Pump shaft | Chrome steel (X20Cr13 / 1.4021) EN 10088 - 3 | Chrome steel (X20Cr13 / 1.4021) EN 10088 - 3 |
| 006 | Feather key | Chrome-nickel-molybdenum steel (X6CrNiMoTi 17-12-2 / 1.4571) EN 10088 - 3 | Chrome-nickel-molybdenum steel (X6CrNiMoTi 17-12-2 / 1.4571) EN 10088 - 3 |
| 035 | Mechanical seal | Carbon / ceramic / Viton (FPM) / chrome- nickel steel (EN 12756 - BVVGG) | Carbon / ceramic / Viton (FPM) / chrome- nickel steel (EN 12756 - BVVGG) |
| 036 | Washer | Chrome-nickel steel (X10CrNiS 18-9 / 1.4305) EN 10088 - 3 | Chrome-nickel steel (X10CrNiS 18-9 / 1.4305) EN 10088 - 3 |
| 037 | Set screw | Chrome-nickel-molybdenum steel (X5CrNiMo 17-12-2 / 1.4401) EN 10088 - 2 | Chrome-nickel-molybdenum steel (X5CrNiMo 17-12-2 / 1.4401) EN 10088 - 2 |
| 047 | Impeller | Cast aluminium bronze (G-CuAl10Fe5Ni5 / CC33G-GS) EN 1982 | Cast chrome-nickel-molybdenum steel (G-X6CrNiMo 18-10 / 1.4408) EN 10213-4 |
| 048 | Tolerancing for impeller | Chrome-nickel steel (X12CrNi 17-7 / 1.4310) EN 10088 - 2 | Chrome-nickel steel (X12CrNi 17-7 / 1.4310) EN 10088 - 2 |
| 049 | Port plate | Ceramic - C221 EN 60672 - 1 | Ceramic - C221 EN 60672 - 1 |
| 050 | Valve plate | Teflon (PTFE) | Teflon (PTFE) |
| 051 | Intercepting plate | Chrome-nickel-molybdenum steel (X10CrNiMoTi 18-10 / 1.4571) EN 10088 - 2 | Chrome-nickel-molybdenum steel (X10CrNiMoTi 18-10 / 1.4571) EN 10088 - 2 |
| 057 | Gasket for cover | Nitrile-butadiene-caotchouc (NBR) ISO 1629 | Viton (FPM) |
| 061 | Cover | Grey cast iron (EN-GJL HB 195 / EN-JL2030) EN1561 | Cast chrome-nickel-molybdenum steel (G-X6CrNiMo 18-10 / 1.4408) EN 10213-4 |
| 063 | Screw | Steel (DIN ISO 8992) | Steel (DIN ISO 8992) |
| 068 | Plug screw | Machining steel, lead alloyed (11SMnPb30 / 1.0718) EN 10087 | Chrome-nickel-molybdenum steel (X10CrNiMoTi 18-10 / 1.4571) EN 10088 - 3 |
| 069 | Sealing ring | Teflon (PTFE) | Teflon (PTFE) |
| 070 | O-Ring | FPM (flour rubber) | FPM (flour rubber) |
| 071 | Pipe of cavitation protection | Chrome-nickel-molybdenum steel (X10CrNiMoTi 18-10 / 1.4571) EN 10088 - 3 | Chrome-nickel-molybdenum steel (X10CrNiMoTi 18-10 / 1.4571) EN 10088 - 3 |
| 072 | Washer for cavitation protection | Chrome-nickel steel (X5CrNi 18-10 / 1.4301) EN 10088 - 3 | Chrome-nickel steel (X5CrNi 18-10 / 1.4301) EN 10088 - 3 |
| 079 | Plug screw | Machining steel, lead alloyed (11SMnPb30 / 1.0718) EN 10087 | Chrome-nickel-molybdenum steel (X5CrNiMo 17-12-2 / 1.4401) EN 10088 - 3 |
| 080 | Sealing ring | Teflon (PTFE) | Teflon (PTFE) |



Changes in particular the quoted performance curve, datas and weights without prior notice. The figures are without obligations.

Gardner Denver

*Elmo Rietschle is a brand of the
Gardner Denver Blower Division*

info@de.gardnerdenver.com
www.gd-elmorietschle.com

Gardner Denver Schopfheim GmbH

Roggenbachstraße 58
79650 Schopfheim - Germany

Tel.: +49 7622 392-0
Fax: +49 7622 392-300

Gardner Denver Deutschland GmbH

Industriestraße 26
97616 Bad Neustadt - Germany

Tel.: +49 9771 6888-0
Fax: +49 9771 6888-4000