



Radial blowers
Vacuum version

Propulsores radiales
Versión a vacío

Turbines centrifuges
Exécution d'aspiration

Turbinas radiais
Versão a vácuo

F-CEV-S...

F-CEV 3709-S3

F-CEV 3709-S4

F-CEV 3709-S5

F-CEV 3718-S3

F-CEV 3718-S4

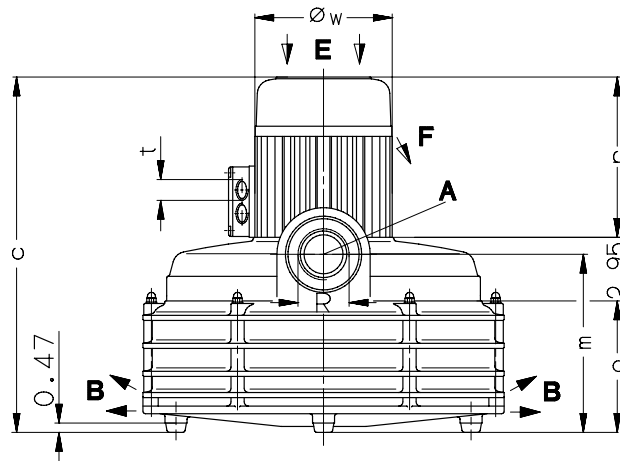
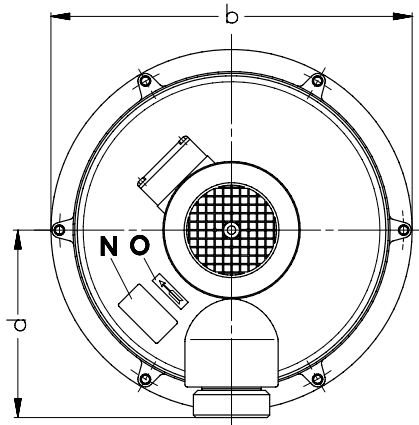

[inches]

A	Vacuum connection	Conexión vacío	Raccord du vide	Conexão do vácuo
B	Exhaust	Escape	Refolement	Exaustão
E	Cooling air entry	Entrada aire refrigerante	Entrée air refroidissement	Entrada do ar refrigerante
F	Cooling air exit	Salida aire refrigerante	Sortie air refroidissement	Saída do ar refrigerante
N	Data plate	Placa fecha	Etiquette caractéristique	Placa da data
O	Rotation arrow	Dirección de rotación	Flèche sens rotation	Direção da rotação

F-CEV		3709-S3	3709-S4	3709-S5	3718-S3	3718-S4
[inches]	b	16.77	16.77	16.77	17.56	17.56
	c	16.54	17.83	20.00	19.33	21.30
	d	8.62	8.62	8.62	9.21	9.21
	m	8.31	9.61	9.61	10.24	12.13
	o	6.14	7.44	8.74	8.07	9.96
	r	7.44	7.44	8.31	8.31	8.39
	t	M 20 x 1.5	M 20 x 1.5	M 20 x 1.5	M 20 x 1.5	M 25 x 1.5
	øw	6.38	6.38	6.38	6.38	7.09
	R	2" NPT	2" NPT	2" NPT	3" NPT	3" NPT

DA 702

1.1.2004

**Gardner Denver
Hanover Inc.**

7222 Parkway Drive
HANOVER, MD 21076
USA

Phone +1 410 / 712 4100

Fax +1 410 / 712 4148

e-mail: sales.hanover@
gardnerdenver.com

www.gd-elmoietschle.com

F-CEV		3709-S3	3709-S4	3709-S5	3718-S3	3718-S4
3~	50 Hz	230/400V ± 10 %				
	60 Hz	230/460V ± 10 %				
kw	50 Hz	0.55	0.75	1.1	1.1	1.5
	60 Hz	0.65	0.90	1.3	1.3	1.8
A	50 Hz	2.85/1.65	5.4/3.1	5.2/3.0	5.4/3.1	6.1/3.5
	60 Hz	3.3/1.65	4.3/2.15	6.4/3.2	6.4/3.2	7.7/3.85
rpm	50 Hz	2850				
	60 Hz	3450				
dB(A)	50 Hz	72	73	73	75	75
	60 Hz	73	74	74	76	76
lbs		66.2	83.8	92.6	83.8	92.6

ZMS		#	#	#	#	#

cfm	Capacity	Capacidad	Volume engendré	Capacidade
in. water	Pressure difference	Diferencia de presión	Pression différentielle	Pressão diferencial
V	Vacuum operation	Operación vacío	Fonction dépression	Operação do vácuo
3~	Motor version	Versión motor	Exécution moteur	Versão do motor
kw	Motor rating	Datos motor	Puissance moteur	Potência do motor
A	Full load amperage	Amperaje de plena carga	Intensité absorbée	Amperagem da carga total
rpm	Speed	Velocidad	Vitesse rotation	Velocidade
dB(A)	Average noise level	Nivel de ruido medio	Niveau sonore moyen	Nível médio de ruído
lbs	Weight	Peso	Poids	Peso
	Accessories	Accesorios	Accessoires	Accessórios
ZMS	Motor starter	Arranque motor	Disjoncteur moteur	Arranque do motor

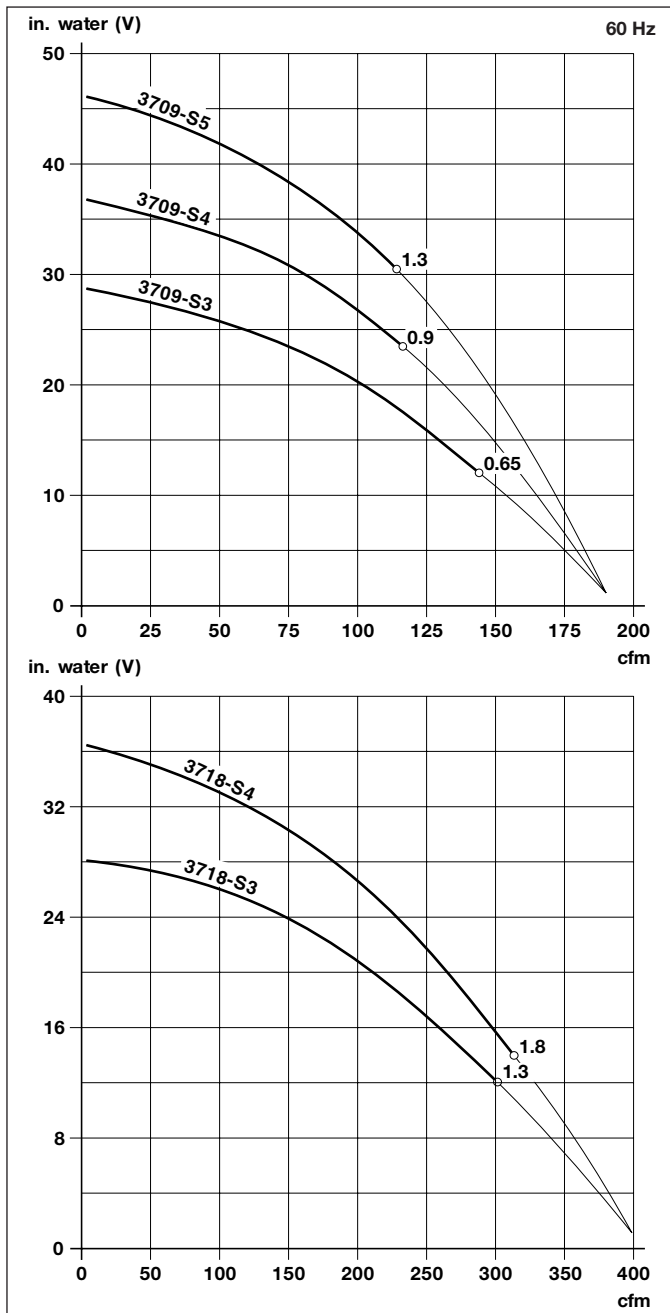
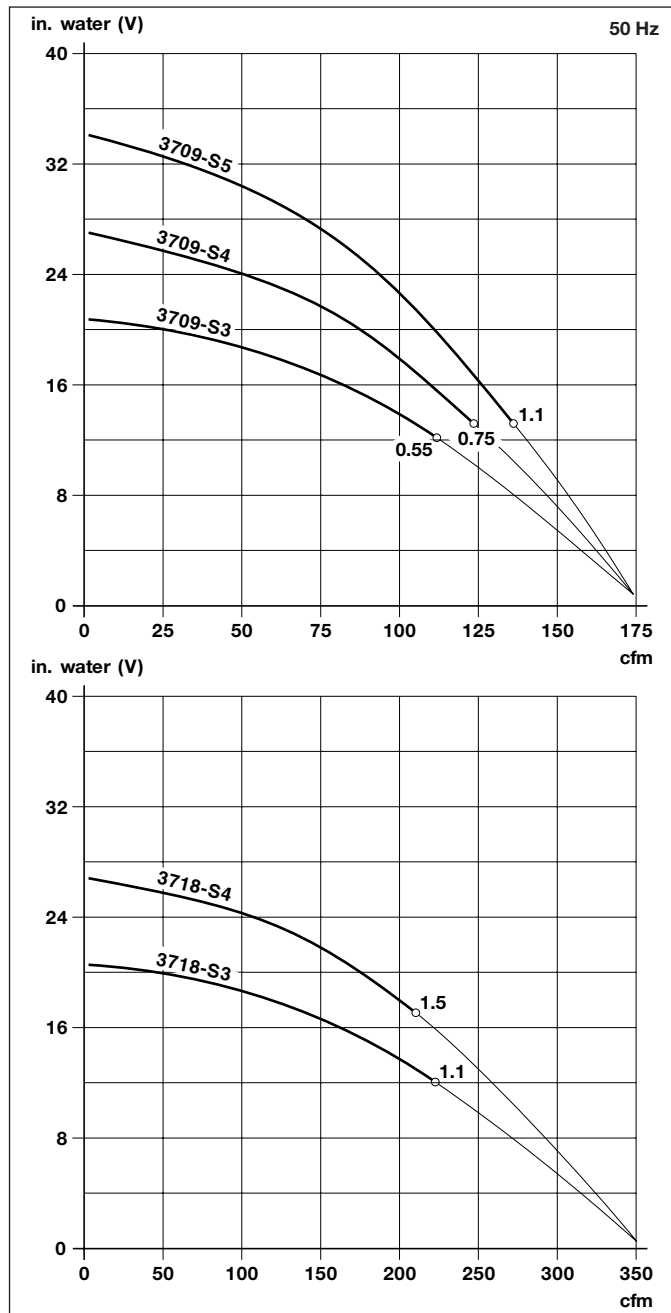

Curves have a tolerance of ± 10 % and refer to free air at 1 standard atmosphere and 20° C (68° F)./ Las curvas tienen una tolerancia de ± 10 % y se refieren al aire libre a 1 atmosfera estándar de presión y a 20° C (68° F) de temperatura./ Les courbes ont une tolérance de ± 10 % et sont établies à l'atmosphère de 1 bar (abs.) à 20° C (68° F)./ As curvas têm uma tolerância de ± 10 % referem-se ao ar livre a uma atmosfera padrão 1 e a 20° C (68° F).

Technical information is subject to change without notice!./ La información técnica está sujeta a cambios sin previo aviso!./ Sous réserve de modification technique./ A informação técnica está sujeita a mudança sem aviso prévio! # on request # on pedido # sur demande # a pedido