

Supplementary instructions L-BV2, L-BV5

Supplement to instruction manual 610.44440.40.000

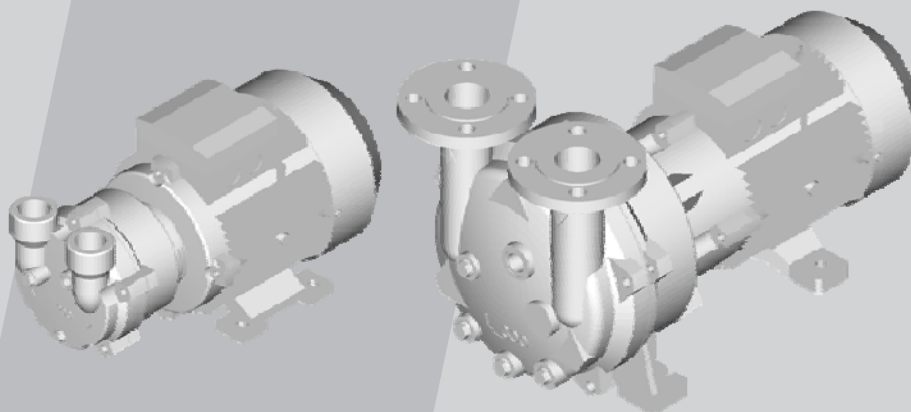

Devices of group II, category 2G



2BV2 060
2BV2 061
2BV2 070
2BV2 071
2BV5 110
2BV5 111
2BV5 121
2BV5 131
2BV5 161



L-Serie
L-Series

Flüssig-
keitsring
Liquid Ring



Content

Concerning 1 Safety2
 Concerning 1.2 General safety instructions.2
 Concerning 2 Correct use of the equipment3
 Concerning 3 Technical Data5
 Concerning 3.3 Operating conditions,
 normal operation.....5
 Concerning 5 Installation.....5
 Concerning 5.1 Installing the unit5
 Concerning 5.2 Connecting the unit
 mechanically.....5
 Concerning 5.2.1 Connecting the suction
 and discharge branches5
 Concerning 5.2.3 Connecting up system
 components.....5
 Concerning 5.2.4 Ancillaries8
 Concerning 5.3 Connecting the motor
 electrically.....8
 Concerning 5.3.2 Operating with a
 frequency converter.....8
 Concerning 7 Operation8
 Concerning 9 Maintenance8
 Concerning 9.1 Servicing.....8
 EU Declaration of conformity.....9
 Form for statement on safety 10

Concerning 1 Safety

Concerning 1.2 General safety instructions

⚠ WARNING

The respective national accident prevention regulations must be complied with!

⚠ WARNING

Improper handling of the system can result in serious or even fatal injuries!

Operating manual 610.44440.40.000 as well as this supplementary operating manual:

- must be read and understood before commencing any work on or with the unit,
- must be strictly adhered to.
- must be available where the unit is used.

⚠ WARNING

Improper handling of the system can result in serious or even fatal injuries!

All work on and with the system (transport, installation, commissioning, decommissioning, maintenance, disposal) may only be carried out by trained and reliable skilled staff!

Concerning 2 Correct use of the equipment

Point 2 "Intended Use" from 610.44440.40.000 is replaced by:

This operating manual

- is applicable to L-Series Liquid ring vacuum pumps / compressors (units) types:
2BV2 060 2BV2 061 2BV2 070 2BV2 071
2BV5 110 2BV5 111 2BV5 121 2BV5 131
2BV5 161
Additional instructions Concerning explosion protection according to Guideline 94/9/EG
- contains instructions for the unit's transportation, installation, start-up, operation, shut-down, storage, maintenance and disposal,
- must have been read and properly understood by operating and maintenance staff before beginning any work with or on the unit.
- must be complied with and
- must be at hand where the unit is installed.

Operating and maintenance personnel

Operating and maintenance personnel for G-BH1 units must be trained and authorised for the work to be carried out.

Work on electrical installations may only be carried out by an electrician specialist.

An electrician specialist is someone who can evaluate and identify potential risks for the assigned task as a result of their technical training, knowledge and experience as well as knowledge about relevant regulations.

G-BH1 units

- create a vacuum or overpressure.
- are used to extract, deliver and compress the following gases / vapours:
 - all dry and damp gases which are not explosive, combustible, aggressive or poisonous,
 - air or air-vapour mixtures.
 - in the case of aggressive or poisonous gases / vapours, please consult the manufacturer.
 - the gases / vapours must be free of solid matter.
Small quantities of light suspended matter or liquids can be conveyed along too.
- are suitable for a deep vacuum range.
- are equipped with RL 94/9/EG three-phase drive motors. For more detailed information please consult the motor manufacturer's accompanying operating instructions.
- are available in two constructions:
 - Construction for normal requirements
 - Construction for higher corrosion-resistance and hygiene requirements (only 2BV2 070. 2BV2 071 and 2BV5 ..)
- are designed for industrial plants.
- are designed for continuous operation.

When operating the units, the limiting values listed in chapter 3 operating manual 610.44440.40.000 "Technical Data" are to be complied with.

Scope of application for units according to Guideline 94/9/EG

Inside area of explosion prevention design

G-BH1 units are suitable for conveying gases/vapours where a potentially explosive atmosphere is occasionally expected to be present.

This specification includes category 2G for the internal space of the units.

If the specified maximum temperatures are complied with, the units are suitable for temperature class T4.

Surrounding area

When rating the device category, both the place where it is installed and its internal space must be taken into consideration.

Installing G-BH1 units for category 2G is allowed for areas where potentially explosive gases / vapours are expected to occur occasionally.

If the specified maximum temperatures are complied with, the units are suitable for temperature class T3.

G-BH1 unit operating liquid

 WARNING
The ignition temperature of the operating fluid must be above 150°C [150.00°F]. The chosen operating liquid must comply with the requirements / properties stated below. It must not corrode or destroy the pump components used.

 WARNING
Monitoring of the operating liquid status before starting up as well as monitoring of trouble-free feeding of the operating liquid while in operation should be built into the system. The system must shut down if there is a failure in the operating fluid feed. Operating without operating fluid must be avoided under all circumstances.

NOTE
When using operating fluids with a heat capacity of < 3 kJ/kg K, or a boiling point which does not lie 20 K above the input temperature, consult the manufacturer.

Operating liquid type:

Normally use water with a pH-value between 6 and 9, or any other liquid compatible with the process.

It must be free of:

- Foreign matter and objects:
- Crystalline precipitate substances
- Substances which tend to stick or jam

No precipitate substances may be produced from the operating fluid during the sealing process. Likewise, no substances may be used which tend to polymerise of their own accord or when in contact with propellant gas.

Compatibility must be checked with regards to chemical reactions between the operating liquid and the slide ring seal, the operating fluid and other pump parts as well as the operating fluid and the propellant gas.

Foreseeable misuse

The following are forbidden:

- Use of the unit 2BV2 060 2BV2 061 2BV2 070 2BV2 071 2BV5 110 2BV5 111 2BV5 121 2BV5 131 2BV5 161 in non-industrial plants, unless the necessary precautions and protective measures have been taken at the plant, e.g. protection against contact by children's fingers.
- Setting up and use of units in zones 0, 20, 21 and 22.
- The extraction, transport and condensing of aggressive or poisonous media unless the units are specifically designed for such media.
- to evacuate, convey and compress explosive, inflammable, or aggressive mediums, which could damage the slide ring seal.
- To evacuate, convey and compress gases or gas mixtures which are explosive when air is not present, or may change the unit's safety-relevant material properties.
- Operation with a frequency converter.
- Operation of the unit at any values other than those specified in chapter 3 "Technical data" in the 610.44440.40.000 operating manual.

Modifications to the units are forbidden for safety reasons.

The operator is not allowed to carry out maintenance, servicing and repair work which requires the machine to be dismantled.

Concerning 3 Technical Data

Concerning 3.3 Operating conditions, normal operation

Temperatures

Temperature of the operating liquid	
[°C]	[°F]
max. +65	max. +149
min. +5	min. +41
Nominal value:	
+15	+59

Pressures

Minimum suction pressure of the gas

If an explosive gas mixture should arise due to ambient air entering the unit, the use of process gas must be ensured for the cavitation protection. If the unit suction pressure ($p_{1 \text{ min}}$) doesn't stand at a minimum of 50 mbar above the vapour pressure (p_{Vapour}) of the operating fluid ($\Rightarrow p_{1 \text{ min}} \leq p_{\text{Vapour}} + 50 \text{ mbar}$) or when there are changes in the operating conditions (media, temperatures), consult the manufacturer.

Concerning 5 Installation

Concerning 5.1 Installing the unit

Conditions for setting up the system:

The type of protection on the drive motor must correspond to the ambient atmosphere requirements in accordance with guideline 94/9/EG.

The equipment and components added to the unit must also correspond to the requirements for device group II category in guideline 94/9/EG.

The equipment and components added to the unit must also correspond to the requirements for device group II category in guideline 94/9/EG, unless they have their own ignition source. The bleeder resistance for each installed accessory or attached part as well as for the unit must have $< 10^6 \text{ Ohm}$ to ground when assembled!

Concerning 5.2 Connecting the unit mechanically

Concerning 5.2.1 Connecting the suction and discharge branches

In order to prevent overloading from throttle on the discharge side, pressure monitoring (G2, Fig. 1, page 6) must be installed on the other side of the unit's gas output flange. If the maximum outlet pressure $p_{2 \text{ max}}$ specified in the 610.44440.40.000 operating manual section 3.3, "Operating conditions, normal operation" is exceeded, the equipment must switch off. If operating with cavitation protection, the line must have sufficient electrical conductivity (bleeder resistance $< 10^6 \text{ } \Omega$).

Foreign bodies must be prevented from getting into the pump.

If there is danger of foreign bodies getting in while the pump is operating or switched off, suitable filters must be attached.

Concerning 5.2.3 Connecting up system components

The built-in monitoring systems must be fully functional independently from one another. The systems must also remain independent if computer-programmed controls are used.

Monitoring of continual operating liquid feed

Monitoring of continual operating liquid feed is compulsory. Monitoring can be ensured by the following alternative systems:

- Measuring the operating liquid volume flow (F1, Fig. 1, page 6) with suitable sensor and analysis device. Switching commands must operate directly on the switches. When using a volume flow device which can block, an additional redundant monitoring system must be provided. Specifications regarding failure safety as well as calibration and servicing intervals should be taken from the monitoring device operating manual.

Disconnection condition:

Volume flow $\leq 50 \%$ of the design operating fluid flow

(see 610.44440.40.000 operating manual section 3.3, "Operating conditions, normal operation")

b) Operating fluid temperature measurement in the drain tapping (F2, Fig. 1, page 6), or on the unit housing (F5, Fig. 1, page 6) with suitable temperature sensor.

Disconnection condition:

Temperature $\geq 60\text{ }^{\circ}\text{C}$ (140 $^{\circ}\text{F}$)

The measurement and control device must be suitable or certified to take reliable measurements for disconnection conditions and shut down the equipment if necessary. The device must be certified with regard to its point of installation in accordance with its category.

It is recommendable to implement the monitoring systems in accordance with EN ISO 13849.

The volume flow measurement sensor must be suitable for the area prevailing in the measuring point internal space.

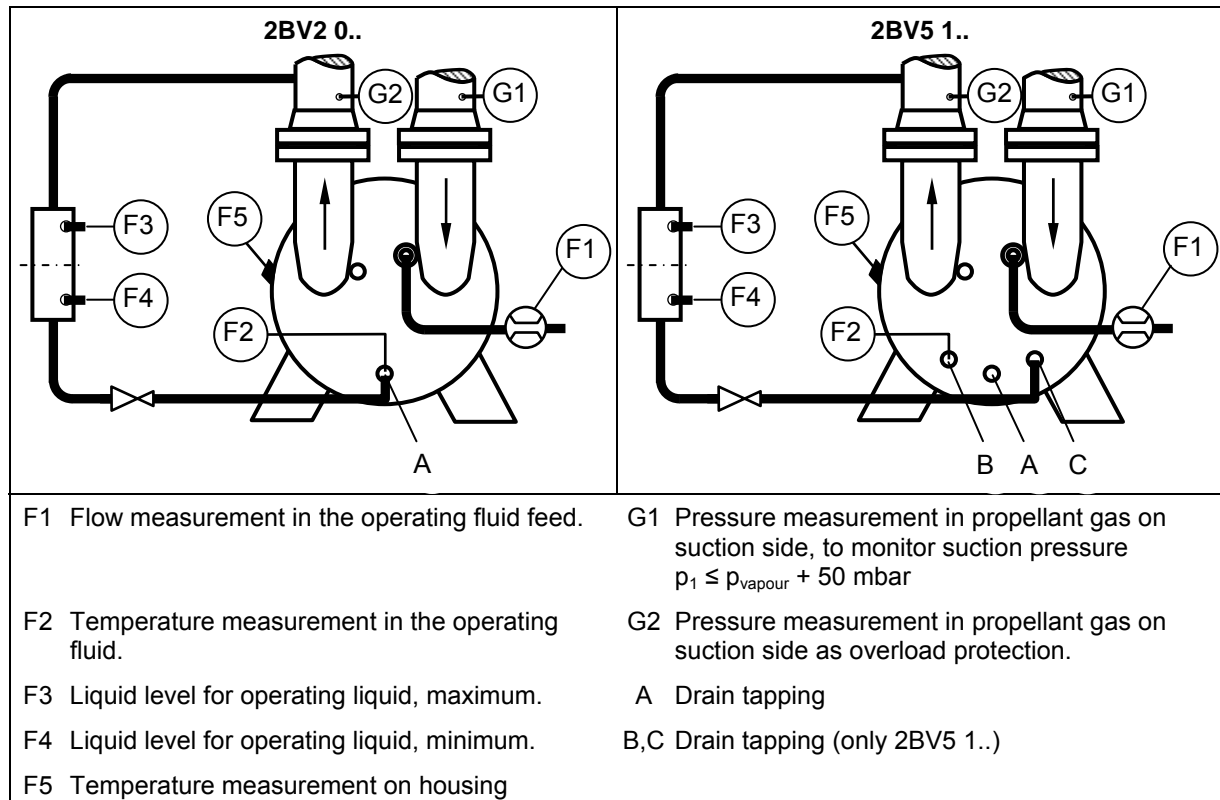

Fig. 1: Position of measuring points

Monitoring liquid level before starting up

Monitoring the liquid level before starting up is compulsory.

Monitoring can be ensured, for instance, by inductive proximity switches, solenoid-operated sensors, or pressure-dependent sensors, each combined with an analysis device.

The liquid level switches (F3, F4, Fig. 1, page 6) should be installed in the liquid level monitoring device (position Fig. 1 page 6).

The monitoring device sensors must be non-corrosive and certified for category 2 if there is direct contact with the internal space.

The measurement and control device must be suitable or certified to take reliable measurements for disconnection conditions and shut down the equipment if necessary.

The device must be certified with regard to its point of installation in accordance with its category.

It is recommendable to implement the monitoring systems in accordance with EN ISO 13849.

The liquid level monitoring sensor must be suitable for the area prevailing in the measuring point internal space.

It must only be possible to turn on the unit if the given fluid level stands between $h_{f\text{ min}}$ and $h_{f\text{ max}}$ (Fig. 2, page 7).

NOTE

The liquid level monitoring device (Fig. 1, page 6) is equipped with a shut-off valve which opens after the unit is switched off and closes again before starting up after the filling level has been regulated.

If a connection between the device and the ambient atmosphere is not possible, or undesirable, due to the type of media used, the line should be routed back into the equipment behind the shut-off valve on the suction side in a suitable way (Fig. 1, page 6).

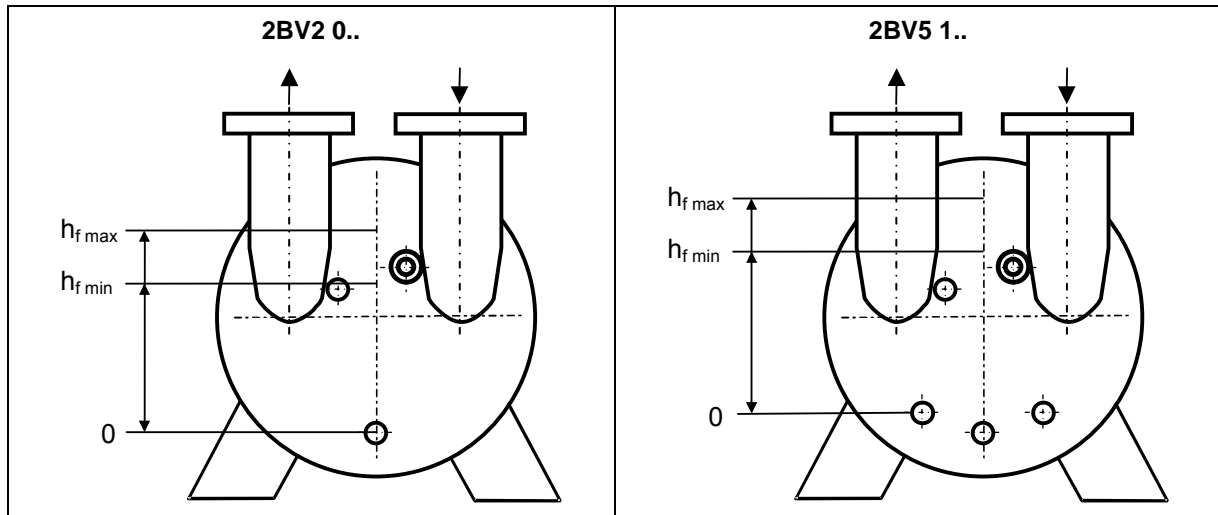

Type	Minimum $h_{f \min}$ [mm]	Maximum $h_{f \max}$ [mm]	Minimum $h_{f \min}$ [inches]	Maximum $h_{f \max}$ [inches]
2BV2 060	75	95	2.95	3.74
2BV2 061				
2BV2 070	95	120	3.74	4.72
2BV2 071				
2BV5 110	116	156	4.57	6.14
2BV5 111				
2BV5 121	130	170	5.12	6.69
2BV5 131	140	185	5.51	7.28
2BV5 161	175	235	6.89	9.25

Fig. 2 Operating liquid level

Concerning 5.2.4 Ancillaries

Operating fluid separator

The 2BX1 102, 2BX2 103 und 2BX1 107 stainless steel separators do not come under guideline 94/9/EG as they don't have their own ignition sources. The propellant gas and the operating fluid must not react chemically to the separator. The separator bleeder resistance must have <math> < 10^6 </math> Ohm to ground when attached or installed!

When a suction-side separator is used, only a pressure-resistant construction is permitted in accordance with guideline 97/23/EG. The standard separator as in the catalogue must not be used.

Check valve

The 2BY6 9-type metal check valves do not come under guideline 94/9/EG as they don't have their own ignition sources. The propellant gas and the operating fluid must not react chemically to the check valve. The check valve bleeder resistance must have <math> < 10^6 </math> Ohm to ground when attached or installed!

Gas ejector

The 2BP5-type metal gas ejectors do not come under guideline 94/9/EG as they don't have their own ignition sources. The propellant gas and the operating fluid must not react chemically to the gas ejector. The gas ejector bleeder resistance must have <math> < 10^6 </math> Ohm to ground when attached or installed! The gas propellant must be free of statically rechargeable particles.

Concerning 5.3 Connecting the motor electrically

The accompanying drive motor operating manual must be strictly adhered to:

Concerning 5.3.2 Operating with a frequency converter

⚠ WARNING
Operating the unit with a converter is not permitted.

Concerning 7 Operation

⚠ DANGER
If the system is shut down by a monitoring system during operation, its cause must be identified and the problem must be rectified before restarting. Do not go below the safety level required by the device category!

Concerning 9 Maintenance

Concerning 9.1 Servicing

The operator is not allowed to carry out any kind of maintenance, servicing and repair work which requires the machine to be dismantled.

Interval	Maintenance procedure
weekly	Remove dust deposits from unit.
2 years or 18,000 operating hours	Ball bearings to be replaced or re-greased by service technician.

**Gardner
Denver**

EU declaration of conformity

Manufacturer: Gardner Denver Deutschland GmbH
P.O. Box 1510
D-97605 Bad Neustadt / Saale

Responsible for documentation: Holger Krause
P.O. Box 1510
D-97605 Bad Neustadt / Saale

Designation: L Series Liquid ring vacuum pump/ compressor
L-BV2, L-BV5

Types	2BV2 060-..D..-Z	2BV2 060-..G..-Z
	2BV2 061-..D..-Z	
	2BV2 070-..D..-Z	2BV2 070-..G..-Z
	2BV2 071-..D..-Z	2BV2 071-..G..-Z
	2BV5 110-..D..-Z	2BV5 110-..G..-Z
	2BV5 111-..D..-Z	
	2BV5 121-..D..-Z	2BV5 121-..G..-Z
	2BV5 131-..D..-Z	
	2BV5 161-..D..-Z	

The liquid ring vacuum pump/compressor described above with motor fitted as per the EC declaration of conformity issued by Siemens complies with the following applicable Community harmonisation legislation:

94/9/EC Directive 94/9/EC of the European Parliament and the Council of 23 March 1994 on the approximation of the laws of the Member States concerning equipment and protective systems intended for use in potentially explosive atmospheres

 **II 2G b c T3**

2006/42/EC Directive 2006/42/EC of the European Parliament and of the Council of 17 May 2006 on machinery, and amending Directive 95/16/EC

The protection targets of the directive 2006/95/EC have been met

Harmonised standards applied:

EN 1012-1:1996 Compressors and vacuum pumps — Safety requirements — Part 1: Compressors

EN 1012-2:1996 Compressors and vacuum pumps — Safety requirements — Part 2: Vacuum pumps

EN 1127-1:2007 atmospheres — Explosion prevention and protection — Part 1: Basic concepts and methodology

EN 13463-1:2001 Non-electrical equipment for potentially explosive atmospheres — Part 1: Basic method and requirements

EN 13463-5:2003 Non-electrical equipment intended for use in potentially explosive atmospheres — Part 5: Protection by constructional safety "c"

EN 13463-6:2005 Non-electrical equipment for use in potentially explosive atmospheres — Part 6: Protection by control of ignition source "b"

The technical documentation is stored at the notified body DEKRA EXAM GmbH, no. 0158 under certification number BVS 03 ATEX H/B 072/ BVS 03 ATEX H/B 073.

Bad Neustadt/Saale, 29.12.2009

(Place and date of issue)

ppa. Fred Bornschlegl

(Name and function)

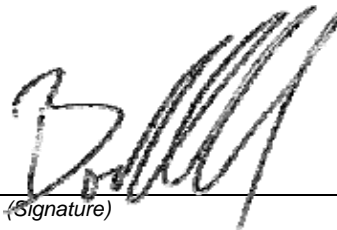

(Signature)

664.44440.40.200



Statement on health safety and on the protection of the environment

- For the safety of our employees and to comply with statutory requirements on handling substances harmful to the health and the environment, this statement must be enclosed, fully completed, with **each** unit/system sent.
- **Without the fully completed statement, repair/disposal is not possible and delays are unavoidable!**
- The statement is to be completed and signed by suitably qualified, authorised personnel at the operating organisation.
- In the case of shipment to Germany, the statement is to be completed in German or English.
- The statement is to be attached to the outside of the packing on shipment.
- If necessary, the carrier is to be informed.

1. **Product designation (type):**

2. **Serial number (no. BN):**

3. **Reason for sending:**

4. **The unit/system**

- has **not** come into contact with hazardous substances. There will be **no** hazards for personnel or the environment during repair/disposal. Continue with "6. Legally binding statement"
- has come into contact with hazardous substances. Continue with "5. Information on the contamination"

5. **Information on the contamination** (if necessary provide more information on an additional sheet)

The unit/system was used in the following application:

.....
and has come into contact with the following classifiable substances or substances presenting a hazard to health/environment:

Trade name:	Chemical designation:	Hazardous substance class:	Properties (e.g. toxic, inflammable, caustic, radioactive):

- The unit/system has been emptied in accordance with the operating instructions, flushed and cleaned externally.
- Safety data sheets in accordance with the applicable regulations are enclosed (..... sheet).
- The following safety precautions are necessary for handling (e.g. personal protective equipment):

.....
.....

6. **Legally binding statement**

I herewith guarantee that the details specified are true and complete and that I, as signatory, am in a position to judge that this is so.

We are aware that we are liable to the contractor for any damages arising from incomplete or incorrect specifications. We are obliged to indemnify the contractor against claims for damages by third parties arising from incomplete or incorrect specifications. We are aware that, irrespective of this statement, we are directly liable to third parties - in particular including the contractor's employees tasked with repair/disposal.

Company/institute:

Name, position: Phone:

Street: Fax:

Post code, city:

Country: Stamp:

Date, signature:

© Gardner Denver Deutschland GmbH

610.00250.40.905

P.O. box 1510

Phone: +49 7622 392 0

E-mail: er.de@gardnerdenver.com

10.2009

97605 Bad Neustadt

Fax: +49 7622 392 300

Internet: www.gd-elmorietschle.com

English



**Elmo
Rietschle**
A Gardner Denver Product

www.gd-elmorietschle.de
er.de@gardnerdenver.com

**Gardner Denver
Schopfheim GmbH**
Roggenbachstraße 58
79650 Schopfheim · Deutschland
Tel. +49 7622 392-0
Fax +49 7622 392-300

**Gardner Denver
Deutschland GmbH**
Industriestraße 26
97616 Bad Neustadt · Deutschland
Tel. +49 9771 6888-0
Fax +49 9771 6888-4000

**Gardner
Denver**

Elmo Rietschle is a brand of
Gardner Denver's Industrial Products
Group and part of Blower Operations.